



# Precast concrete flags, kerbs, channels, edgings and quadrants —

**Part 1: Precast, unreinforced concrete  
paving flags and complementary  
fittings — Requirements and test  
methods**

ICS 91.100.30

## Committees responsible for this British Standard

The preparation of this British Standard was entrusted to Technical Committee B/507, Paving units and kerbs, upon which the following bodies were represented:

Brick Development Association  
 British Cement Association  
 British Ceramic Research Ltd.  
 British Precast Concrete Federation Ltd.  
 Cementitious Slag Makers' Association  
 County Surveyors' Society  
 Department of Transport (Highways Agency)  
 Institution of Highways and Transportation  
 Interlay, the Association of Block Paving Contractors  
 Interpave, the Concrete Block Paving Association  
 Landscape Institute  
 Society of Chemical Industry  
 Stone Federation

The following bodies were also represented in the drafting of the standard, through subcommittees and panels:

British Civil Engineering Test Equipment Manufacturers' Association  
 Institution of Structural Engineers  
 National Federation of Clay Industries Ltd.  
 National Paving and Kerb Association

This British Standard, having been prepared under the direction of the Sector Committee for Building and Civil Engineering, was published under the authority of the Standards Committee and comes into effect on  
 15 September 2001

© BSI 08-2001

First published May 1990  
 Second edition April 1994  
 Third edition September 2001

The following BSI references relate to the work on this British Standard:

Committee reference B/507  
 Draft for comment 99/106276 DC

ISBN 0 580 33309 4

### Amendments issued since publication

Amd. No.	Date	Comments

# Contents

	Page
Committees responsible	Inside front cover
Foreword	iii
<hr/>	
1 Scope	1
2 Normative references	1
3 Definitions	1
4 Materials	3
5 Requirements	3
6 Manufacturer's evaluation of conformity	7
7 Marking	8
8 Test report	8
<hr/>	
Annex A (normative) Manufacturer's evaluation of conformity	9
Annex B (normative) Measurement of the dimensions of a single paving flag	12
Annex C (normative) Sampling and testing of a consignment in case of dispute	14
Annex D (normative) Method for determining weathering resistance	15
Annex E (normative) Method for measuring bending strength	21
Annex F (normative) Method for measuring abrasion resistance	23
Annex G (normative) Method for determining the slip/skid resistance value	30
Annex H (normative) Method for verifying visual properties	31
Annex I (normative) Conformity assessment for bending strength	32
Annex J (informative) Example of a typical production control system	32
<hr/>	
Bibliography	35
<hr/>	
Figure 1 — Dimensions and spacing of flattened domes on tactile crossing paving flags	4
Figure B.1 — Notched straightedge and gauge	13
Figure B.2 — Calibrated square	14
Figure D.1 — Example of the cross-section of a specimen (right) and a specimen seen from above (left)	17
Figure D.2 — Principle of set-up for the freeze/thaw test	18
Figure D.3 — Time-temperature cycle	19
Figure E.1 — Principle of operation of transverse testing machine	21
Figure F.1 — Principle of operation of wearing machine	24
Figure F.2 — Position of the slot in the base of the flow guidance hopper	25
Figure F.3 — Position of the slot relative to the wide abrasion wheel — Cylindrical hopper	26
Figure F.4 — Position of the slot relative to the wide abrasion wheel — Rectangular hopper	27
Figure F.5 — Example of a tested specimen showing a groove	29
<hr/>	
Table 1 — Designated rectangular paving flag sizes	3
Table 2 — Dimensions and spacing of flattened domes on tactile crossing paving flags	4
Table 3 — Tolerances for work dimensions	5
Table 4 — Maximum differences	5
Table 5 — Tolerances for flatness and bow	5
Table 6 — Weathering resistance classes	6
Table 7 — Bending strength classes	6
Table 8 — Abrasion resistance classes	6

	Page
Table 9 — Slip/skid resistance classes	7
Table 10 — Classes and their identification	8
Table A.1 — Periodically repeated type testing	9
Table A.2 — Sampling plan and conformity criteria for initial and further type testing	10
Table B.1 — Dimensions of notched straightedge and gauge	13
Table C.1 — Sampling and testing plan	15
Table C.2 — Sampling and testing plan for additional properties	15
Table D.1 — Co-ordinates of break points	19
Table J.1 — Testing and measuring equipment	32
Table J.2 — Storage and production equipment	32
Table J.3 — Materials inspection	33
Table J.4 — Production process inspection	33
Table J.5 — Product testing	34
Table J.6 — Marking, storage and delivery	34

---

## Foreword

This part of BS 7263 has been prepared by Technical Committee B/507. Together with BS 7263-3:2001 it supersedes BS 7263-1:1994 which is withdrawn.

This revision of part 1 has been prepared to reflect current CEN principles regarding the writing of standards for this type of product: such standards are now performance-based instead of recipe-based. This has entailed taking out the requirements for materials and inserting far more performance requirements. To support this change, test methods have now been included as annexes. This revision has also introduced a requirement for type testing and factory production control, together with an example of a production control procedure.

Users of this standard should be aware that the concept of type testing (see **A.2**) has been brought forward from Harmonized European Standards, and is intended to give the manufacturer and any attestation body confidence that a new or modified product will conform to the performance requirements during regular production runs. The requirements for products to meet this standard are given in clause **5**. The requirements specified in **A.2** are only for type testing.

The following specific changes have been made in this revision:

- a) the dimensional requirements have been removed so that paving flags can be of any shape or size (the shapes and sizes in the previous edition have been retained as designated units);
- b) the water absorption limit has been removed;
- c) the bending load requirement has been replaced by a bending strength requirement and the test method has been modified accordingly;
- d) performance requirements and test methods have been added for:
  - 1) weathering resistance (freeze/thaw);
  - 2) abrasion resistance;
  - 3) slip/skid resistance;
  - 4) visual properties;
- e) for weathering resistance, abrasion resistance and slip/skid resistance, performance classes have been introduced; these include a class for “no performance determined”, which enables the purchaser to request a product appropriate to its intended use and location.

This British Standard is an adaptation of the current draft of the European Standard prEN 1339, following the publication of which as BS EN 1339 this standard, BS 7263-1, will be withdrawn.

Annex A, Annex B, Annex C, Annex D, Annex E, Annex F, Annex G, Annex H and Annex I are normative. Annex J is informative.

A British Standard does not purport to include all the necessary provisions of a contract. Users of British Standards are responsible for their correct application.

**Compliance with a British Standard does not of itself confer immunity from legal obligations.**

### Summary of pages

This document comprises a front cover, an inside front cover, pages i to iv, pages 1 to 35 and a back cover.

The BSI copyright notice displayed in this document indicates when the document was last issued.



## 1 Scope

This part of BS 7263 specifies requirements and test methods for precast, unreinforced concrete paving flags and complementary fittings. It specifies the dimensions of rectangular paving flags designated in the United Kingdom, and the dimensions and shapes of tactile paving flags. It is applicable to precast, unreinforced concrete paving flags and complementary fittings that are particularly for use in external trafficked paved areas.

## 2 Normative references

The following normative documents contain provisions which, through reference in this text, constitute provisions of this part of BS 7263. For dated references, subsequent amendments to, or revisions of, any of these publications do not apply. For undated references, the latest edition of the publication referred to applies.

BS 812-114:1989, *Testing aggregates — Method for determination of the polished-stone value*.

BS 7932:1998, *Method for determination of polished paver value (PPV)*.

BS EN 10083-2:1991, *Quenched and tempered steels — Part 2: Technical delivery conditions for unalloyed quality steels*.

BS EN ISO 4288:1998, *Geometric product specification (GPS) — Surface texture — Profile method — Rules and procedures for the assessment of surface texture*.

BS ISO 8486-1:1996, *Bond abrasives — Determination and designation of grain size distribution — Part 1: Macrogrits F4 to F220*.

## 3 Definitions

For the purposes of this British Standard the following definitions apply:

### 3.1

#### **paving flag**

precast, unreinforced concrete unit used as a surfacing material

### 3.2

#### **tactile paving flag**

paving flag provided with a profiled surface, used to give warning of hazards, or to enable locations to be recognized

NOTE A crossing flag is an example of a tactile paving flag.

### 3.3

#### **complementary fitting**

unit that is used to infill and enable an area to be completely surfaced

NOTE A complementary fitting can be a piece of a paving flag.

### 3.4

#### **upper face**

surface intended to be seen when in use

### 3.5

#### **bed face**

surface generally parallel to the upper face and in contact with the bedding after laying

### 3.6

#### **chased side face**

side face of a paving flag having a recessed profile



**3.7**

**facing layer**

layer of concrete providing the upper face of a paving flag, of different material and/or properties to the main body or backing layer

**3.8**

**spacer nib**

small protruding profile on a side face of a paving flag

**3.9**

**arris**

part of a paving flag where two faces meet

NOTE An arris can be bevelled, rounded, chamfered, radiused or splayed.

**3.10**

**chamfer**

bevelled arris with horizontal or vertical dimensions exceeding 2 mm

**3.11**

**secondary processing**

manufacturing process to texture a whole paving flag or any of its surfaces, carried out after basic manufacture before or after hardening

**3.12**

**work dimension**

dimension of a paving flag specified for its manufacture

**3.13**

**actual dimension**

dimension of a paving flag as measured

**3.14**

**overall length**

length of the longer side of the smallest rectangle that encloses the entire paving flag, excluding any spacer nibs

**3.15**

**overall width**

width of the shorter side of the smallest rectangle that encloses the entire paving flag, excluding any spacer nibs

**3.16**

**thickness**

distance between the upper face and the bed face of a paving flag

**3.17**

**slip resistance**

ability of a paving flag to resist relative movement between a pedestrian foot and the trafficked flag surface

**3.18**

**skid resistance**

ability of a paving flag to resist relative movement between a vehicle tyre and the trafficked flag surface

## 4 Materials

The materials used for the manufacture of paving flags shall be at the manufacturer's discretion. Details of the materials used shall be declared in the manufacturer's production control documentation (see Annex A).

## 5 Requirements

### 5.1 General

Paving flags shall be produced either with a single type of concrete throughout or with different facing and backing layers. If paving flags are produced with a facing layer this shall, when measured in accordance with Annex B, have a minimum thickness of 12 mm, excluding isolated particles of aggregate protruding into the facing layer, over the area declared by the manufacturer. The facing layer shall be bonded to the backing layer.

It shall be permissible for a "square" arris to be either bevelled or rounded. A "square" arris shall have horizontal and vertical dimensions not exceeding 2 mm. The dimensions of a chamfer shall be at the discretion of the manufacturer. The dimensions shall be declared in the manufacturer's production control documentation (A.3.1).

NOTE A bevelled arris with dimensions exceeding 2 mm is described as chamfered.

If a paving flag is produced with functional and/or decorative profiles, these profiles shall not be included in the work dimensions of the paving flag. If a paving flag is produced with surfaces that are textured, secondary processed or treated chemically, these finishes or treatments shall be at the discretion of the manufacturer. All finishes and treatments shall be declared in the manufacturer's production control documentation (A.3.1).

In the event of a dispute regarding the quality of a consignment of paving flags, the procedure specified in Annex C shall be followed.

### 5.2 Shape and dimensions

#### 5.2.1 General

NOTE All dimensions in this subclause are work dimensions.

Excluding complementary fittings, the overall length and the overall width of a paving flag shall not exceed 1 m.

Excluding complementary fittings, the length of a paving flag divided by its thickness shall be greater than 4.

#### 5.2.2 Work dimensions

The work dimensions of rectangular paving flags of designations A to G shall be as specified in Table 1. The work dimensions for paving flags of other shapes and sizes shall be at the discretion of the manufacturer. The work dimensions used for these paving flags shall be declared in the manufacturer's production control documentation (A.3.1). Tactile crossing paving flags shall be provided with flattened domes on the wearing surfaces. The flattened domes shall have the dimensions and spacings specified in Figure 1 and Table 2.

Table 1 — Designated rectangular paving flag sizes

Paving flag designation	Nominal size	Work dimensions	Thickness
	mm	mm	mm
A	600 × 450	598 × 448	50 or 63
B	600 × 600	598 × 598	50 or 63
C	600 × 750	598 × 748	50 or 63
D	600 × 900	598 × 898	50 or 63
E	450 × 450	448 × 448	50 or 70
F	400 × 400	398 × 398	50 or 65
G	300 × 300	298 × 298	50 or 60

NOTE Tactile paving flags (designated type T) are normally available in sizes E, F and G. Tactile crossing paving flags are thus designated type TC/E, TC/F or TC/G depending on their size.

Licensed Copy: Ibcvzr Ibcvzr, University of Loughborough, 24 June 2003, Uncontrolled Copy, (c) BSI

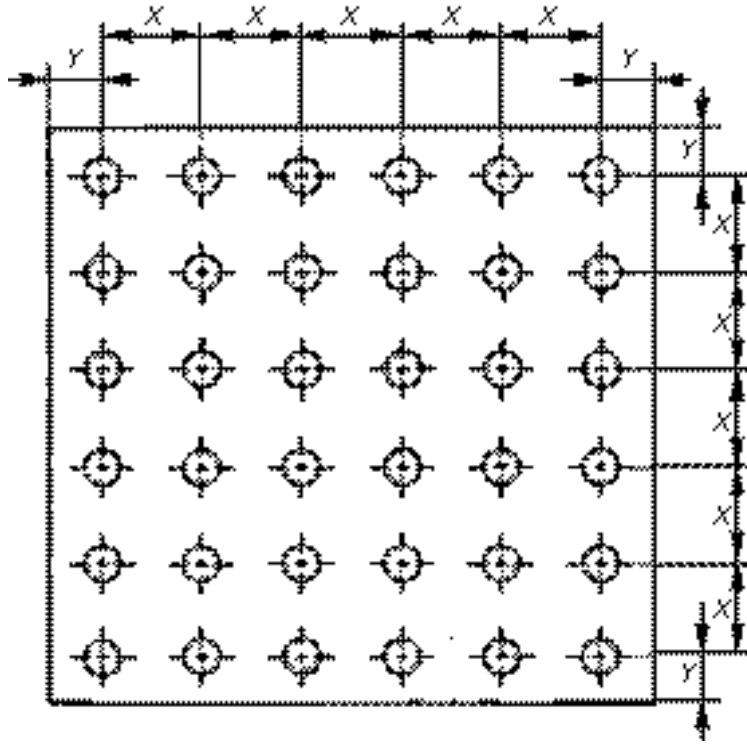

a) Plan

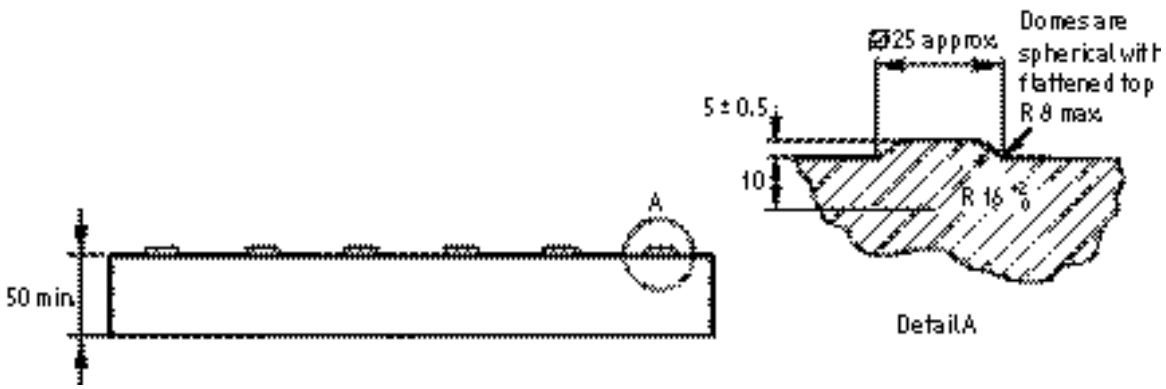

b) Elevation

**Figure 1 — Dimensions and spacing of flattened domes on tactile crossing paving flags**

**Table 2 — Dimensions and spacing of flattened domes on tactile crossing paving flags**

Tactile crossing flag type	Dimension X mm	Dimension Y mm
TC/E	64	33
TC/F	66.8	33
TC/G	75	37.5
Tolerance: ±2		

### 5.2.3 Spacer nibs, draw, and chased and profiled side faces

If a paving flag is produced with spacer nibs, a draw, or chased and profiled side faces, the work dimensions of these items shall be at the discretion of the manufacturer. The work dimensions of these items shall be declared in the manufacturer's production control documentation (see A.3.1).

### 5.2.4 Tolerances

When the dimensions of a single rectangular paving flag are measured in accordance with Annex B, the tolerances shall be as specified in Table 3.

**Table 3 — Tolerances for work dimensions**

Class	Tolerance	
	Length and width mm	Thickness mm
D1	±5	±3
D2	±2	±3

The difference between any two measurements of the length, width and thickness of a single paving flag shall be less than 3 mm.

For the dimensions of non-rectangular paving flags, the tolerances shall be at the discretion of the manufacturer. These tolerances shall be declared in the manufacturer's production control documentation (A.3.1).

The maximum difference between the measurements of the two diagonals of a rectangular paving flag shall be no greater than the differences specified in Table 4.

**Table 4 — Maximum differences**

Class	Length of diagonal mm	Maximum difference mm
X1	up to and including 300	not applicable
	over 300, up to and including 850	5
	over 850	8
X2	up to and including 300	not applicable
	over 300, up to and including 850	3
	over 850	6

For paving flags with an upper face that is intended to be plane, the tolerances for flatness and bow shall be as specified in Table 5.

**Table 5 — Tolerances for flatness and bow**

Length of straight edge mm	Maximum convex mm	Maximum concave mm
up to 300	not applicable	not applicable
300	1.5	1.0
400	2.0	1.5
500	2.5	1.5
800	4.0	2.5

### 5.3 Physical and mechanical properties

#### 5.3.1 Complementary fittings

When complementary fittings cannot be tested according to this part of BS 7263, they shall be deemed to conform to this part of BS 7263, provided that they have at least the same concrete quality as paving flags that conform.

#### 5.3.2 Weathering resistance

When paving flags are tested in accordance with Annex D, classes shall be assigned to them according to the mean value of the test results as specified in Table 6. Families of paving flags that have not been tested for weathering resistance shall be assigned class W1.

**Table 6 — Weathering resistance classes**

Class	Mass loss after weathering test
	mean value (kg/m <sup>2</sup> )
W1	No performance determined
W2	≤1.0, no individual value >1.5
W3	Manufacturer's declared value (A.3.1)
NOTE The manufacturer's declared value is usually applied to secondary processed products.	

#### 5.3.3 Bending strength

When paving flags are tested in accordance with Annex E, classes shall be assigned to them according to the mean bending strength specified in Table 7. No individual result shall be less than the minimum bending strength for the appropriate strength class.

**Table 7 — Bending strength classes**

Class	Mean bending strength	Minimum bending strength
	MPa	MPa
B1	3.7	3.0
B2	5.3	4.2

#### 5.3.4 Abrasion resistance

When paving flags are tested in accordance with Annex F, classes shall be assigned to them according to the values specified in Table 8. No individual result shall be greater than the specified value. Families of paving flags that have not been tested for abrasion resistance shall be assigned class A1.

**Table 8 — Abrasion resistance classes**

Class	Degree of abrasion
	mm
A1	No performance determined
A2	30
A3	26
A4	23

### 5.3.5 Slip/skid resistance

When paving flags are tested in accordance with Annex G, classes shall be assigned to them according to the mean value of the test results as specified in Table 9. The slip/skid resistance value shall be the lower of the values obtained for the unpolished skid resistance and the polished pendulum test. Families of paving flags that have not been tested for slip/skid resistance shall be assigned class S1.

NOTE This is not normally required unless paving flags have been subjected to secondary treatment such as grinding and polishing to produce a smooth surface, or to exposure at the surface of a major proportion of aggregates which polish excessively under wear.

**Table 9 — Slip/skid resistance classes**

Class	Mean slip/skid resistance value
	C scale units
S1	No performance determined
S2	$\geq 35$
S3	$\geq 45$
S4	Manufacturer's declared value (A.3.1)
NOTE Paving flags of class S2 are suitable for use in pedestrian areas and paving flags of class S3 are suitable for use in vehicular areas.	

## 5.4 Visual properties

### 5.4.1 Appearance

When examined in accordance with Annex H, the upper face of paving flags shall not exhibit defects such as cracking or flaking.

In the case of two-layer paving flags there shall be no delamination (separation) between the layers.

NOTE Efflorescence is not deleterious to the mechanical and physical performance of paving flags.

### 5.4.2 Texture

If paving flags are produced with a special surface texture, the texture shall be at the discretion of the manufacturer. The properties of the textured surface shall be declared in the manufacturer's production control documentation (see A.3.1). Paving flags with a special surface texture shall be deemed to conform to this part of BS 7263 if, when examined in accordance with Annex H, there are found to be no significant visible differences to any samples supplied by the manufacturer and approved by the purchaser.

### 5.4.3 Colour

NOTE 1 Colours may be provided in a facing layer or throughout a paving flag at the manufacturer's discretion.

Paving flags containing colours shall be deemed to conform to this part of BS 7263 if, when examined in accordance with Annex H, there are found to be no significant differences in colour to any samples supplied by the manufacturer and approved by the purchaser.

NOTE 2 Variations in the colour consistency of paving flags can be caused by unavoidable variations in the shade and properties of the raw materials and by variations in hardening.

## 6 Manufacturer's evaluation of conformity

The manufacturer's evaluation of conformity shall be carried out as specified in Annex A.

Paving flags produced by the manufacturer shall be subjected to type testing in accordance with A.2.

The manufacturer shall also establish and maintain a production control system for product testing in accordance with A.3.

Conformity assessment for bending strength shall be carried out in accordance with Annex I.

NOTE 1 An example of a production control system is given in Annex J.

NOTE 2 The production control system is intended to enable the manufacturer to determine whether the paving flags conform to the requirements of this part of BS 7263 and to demonstrate that paving flags have been assigned the correct class markings.

## 7 Marking

The following particulars relating to paving flags shall be indicated clearly on any one of the delivery note, invoice, packaging, or supplier's certificate or brochure supplied with the consignment of paving flags:

- a) identification of the manufacturer or the factory;
- b) date of production;
- c) class(es) where applicable (see Table 10);
- d) the number of this British Standard<sup>1)</sup>;
- e) identification of the product (i.e. concrete paving flags).

**Table 10 — Classes and their identification**

Parameter	Class marking
Weathering resistance	W1, W2 or W3
Abrasion resistance	A1, A2, A3 or A4
Diagonals	X1 or X2
Dimensions	D1 or D2
Bending strength	B1 or B2
Slip/skid resistance	S1, S2, S3 or S4

## 8 Test report

A test report shall be produced for each test that is performed by an external laboratory. The test report shall contain the following particulars:

- a) name of the organization carrying out the test;
- b) name of the person carrying out the test;
- c) date of the test;
- d) name of the source providing the sample;
- e) sample reference, including the date of production;
- f) name of the person taking the sample;
- g) annex and/or relevant British Standard in which the test method is specified;
- h) name of the test;
- i) test result;
- j) any pertinent remarks about the sample or test result.

<sup>1)</sup> Marking BS 7263-1:2001 on or in relation to a product represents a manufacturer's declaration of conformity, i.e. a claim by or on behalf of the manufacturer that the product meets the requirements of the standard. The accuracy of the claim is solely the claimant's responsibility. Such a declaration is not to be confused with third-party certification of conformity.

## Annex A (normative)

### Manufacturer's evaluation of conformity

#### A.1 General

For the purpose of testing, products shall be grouped into families, where the value of a selected property is common to all products within that family.

NOTE Examples of such families are:

- **strength family**: paving flags manufactured using the same type of materials and production methods, irrespective of dimensions and colours;
- **surface family**: paving flags with face mixes having the same prime aggregate used in the mix, e.g. natural river gravel, crushed granite, porphyry, basalt or limestone, and the same surface treatment of the finished product, irrespective of dimensions and colours.

#### A.2 Type testing

##### A.2.1 Initial type testing

NOTE Where the product has previously been tested in accordance with the procedures in this part of BS 7263, the results may be used to satisfy initial type testing.

Initial type testing shall be performed at the beginning of the manufacture of a new product type or family of product types, or on the setting up of a new production line, to determine whether the properties of the product conform to the requirements of this part of BS 7263.

The sampling, testing and conformity criteria for initial type testing shall be as specified in A.2.3.

##### A.2.2 Further type testing

Whenever a change occurs in the raw materials, the proportions used or the production equipment or process, which would significantly change some or all of the properties of the finished product, the type tests shall be repeated for the selected property.

The sampling, testing and conformity criteria for further type testing shall be as specified in A.2.3.

NOTE Examples of changes necessitating repeat tests are:

- change from natural river gravel to crushed rock aggregates;
- partial substitution of cement by additions;
- partial substitution of aggregate by recycled concrete.

For abrasion, weathering and slip and/or skid resistance, type testing shall be repeated periodically at the frequency specified in Table A.1.

**Table A.1 — Periodically repeated type testing**

Property	Frequency
Abrasion (classes A2, A3 and A4)	Once per year per surface family
Weathering resistance (class W2 only)	Once per year per surface family <sup>a</sup>
Slip and/or skid resistance	Once per year per surface family

<sup>a</sup> If, for a surface family, the result of a type test (mass loss) is lower than 50 % of the required value, the repeated type tests may be carried out every 2 years as long as this condition continues to be fulfilled.



**A.2.3 Sampling, testing and conformity criteria for initial and further type testing**

The number of paving flags to be tested shall be in accordance with Table A.2 for the selected property.

**Table A.2 — Sampling plan and conformity criteria for initial and further type testing**

Property	Requirement specified in	Test method in accordance with	No. of paving flags	Conformity criteria
Shape and dimensions	5.2	Annex B <sup>a</sup>	6 <sup>b</sup>	Each paving flag shall meet the requirements.
Weathering resistance (class W2 only)	5.3.2	Annex D	3	The mean of the three results shall be not greater than 1.0 kg/m <sup>2</sup> and no individual result shall be greater than 1.5 kg/m <sup>2</sup> .
Bending strength	5.3.3	Annex E	6	Class B1: the mean bending strength of the six paving flags shall not be less than 3.7 MPa and no individual paving flag shall have a bending strength less than 3.5 MPa.
				Class B2: the mean bending strength of the six paving flags shall not be less than 5.3 MPa and no individual paving flag shall have a bending strength less than 5.0 MPa.
Abrasion resistance (class A2 only)	5.3.4	Annex F	3	Each paving flag shall meet the requirements.
Slip/skid resistance (only where tested)	5.3.5	Annex G	4	Class S2: the slip/skid resistance value shall be not less than 35.
				Class S3: the slip/skid resistance value shall be not less than 45.
Appearance	5.4.1	Annex H	8 <sup>b</sup>	No paving flag shall show cracking, flaking or delamination <sup>c</sup> .

<sup>a</sup> B.6 applies only to paving flags with a facing layer.  
<sup>b</sup> These paving flags may be used for subsequent tests.  
<sup>c</sup> Delamination applies only to paving flags with a facing layer.

The type tests shall be carried out in accordance with the test methods called up in this part of BS 7263. The test results shall be recorded.

NOTE Type testing is normally carried out with the manufacturer's test equipment.

### A.3 Production control system

#### A.3.1 General

A production control system shall be established, documented and maintained by the manufacturer.

NOTE 1 This is to ensure that the products placed on the market conform to the specified or declared values.

The documentation of the production control system shall contain the following information:

- a) production control procedures and responsibilities;
- b) details of production processes;
- c) materials to be used in the paving flags (see clause 4);
- d) dimensions of any chamfers to be included in the paving flags, if applicable (see 5.1);
- e) details of any finishes or treatments to be used, if applicable (see 5.1);
- f) work dimensions for non-rectangular paving flags, if applicable (see 5.2.2);
- g) work dimensions for any sizes of paving flag other than those listed in Table 1, if applicable (see 5.2.2);
- h) work dimensions of any spacer nibs, draws, or chased and profiled side faces, if applicable (see 5.2.3);
- i) tolerances for non-rectangular paving flags, if applicable (see 5.2.4);
- j) weathering resistance values, if applicable (see 5.3.2 and Table 6);
- k) slip/skid resistance values, if applicable (see 5.3.5 and Table 9);
- l) details of any special surface textures, if applicable (see 5.4.2);
- m) dates and results of inspections;
- n) details of apparatus used in tests;
- o) procedures for dealing with non-conforming products;
- p) action to be taken when control values or criteria are not met;
- q) test reports (see clause 8, B.7, D.7, E.5, F.9 and G.5);
- r) procedures for marking, storage and delivery control.

NOTE 2 An example of a production control system is given in Annex J.

#### A.3.2 Product testing

A sampling plan shall be prepared. Sampling and testing shall be carried out in accordance with this plan. The test results shall be considered by attributes to determine whether or not the products conform to this part of BS 7263.

Product testing shall be carried out either in accordance with the test methods specified in Annex D, Annex E, Annex F, Annex G and Annex H, or by applying alternative test methods with a proven correlation to those specified in Annex D, Annex E, Annex F, Annex G and Annex H.

The results of product testing shall be retained by the manufacturer.

#### A.3.3 Non-conforming products

If the results of the tests on a product are unsatisfactory, the manufacturer shall take the necessary steps in order to rectify the shortcoming.

Products that do not conform to the requirements shall be set aside and marked accordingly.

## Annex B (normative)

### Measurement of the dimensions of a single paving flag

#### B.1 Preparation

Remove all flashings and burrs from the paving flag to be measured.

#### B.2 Overall dimensions

Using measuring equipment with a precision of 0.5 mm, measure the relevant dimensions in two different places for each dimension and record the actual dimensions obtained to the nearest whole number of millimetres.

For a rectangular paving flag, measure the diagonals and record the difference between the two measurements.

#### B.3 Thickness

Using measuring equipment with a precision of 0.5 mm, measure the thickness of the paving flag to the nearest millimetre. Take measurements at four points between 20 mm and 30 mm from the edge and within 100 mm from each corner. Record the four measurements and calculate the mean thickness to the nearest whole millimetre. Calculate and record the maximum difference between any two readings to the nearest whole millimetre.

#### B.4 Flatness and bow

##### B.4.1 Apparatus

**B.4.1.1** *Notched steel straightedge and gauge*, capable of measuring to an accuracy of 0.1 mm over the specified length  $\pm 1$  mm, as shown in Figure B.1 and Table B.1.

##### B.4.2 Procedure

Using the largest appropriate notched straightedge and gauge (**B.4.1.1**), measure the maximum convex and concave deviations along the two diagonal axes of the upper face to the nearest 0.1 mm. Record both results.

#### B.5 Chamfer

##### B.5.1 Apparatus

**B.5.1.1** *Calibrated square*, capable of measuring to an accuracy of 0.5 mm, as shown in Figure B.2.

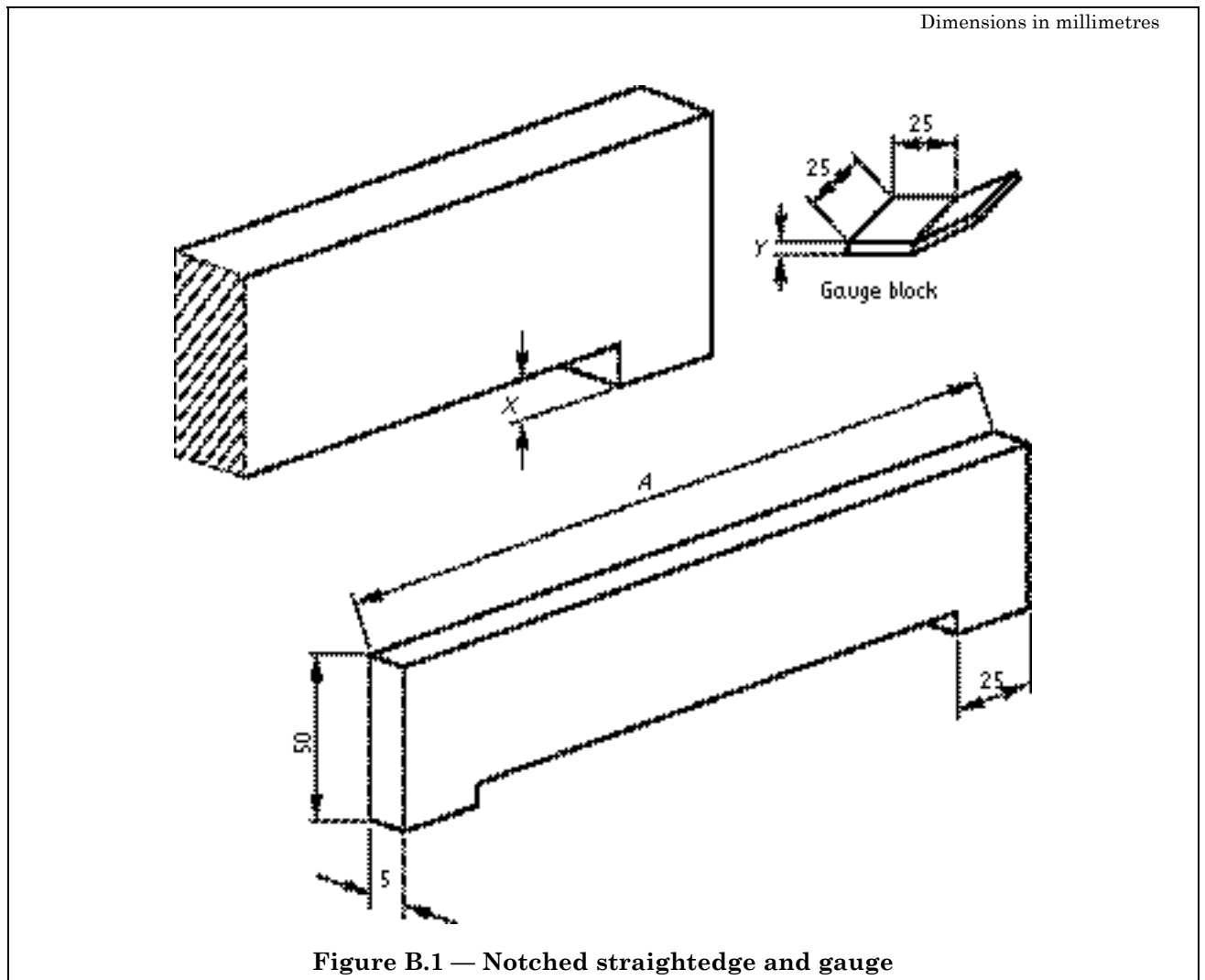

**Table B.1 — Dimensions of notched straightedge and gauge**

Dimension A mm	Dimension X mm	Dimension Y mm
300	1.5	2.5
400	2.0	3.5
500	2.5	4.0
800	4.0	6.5

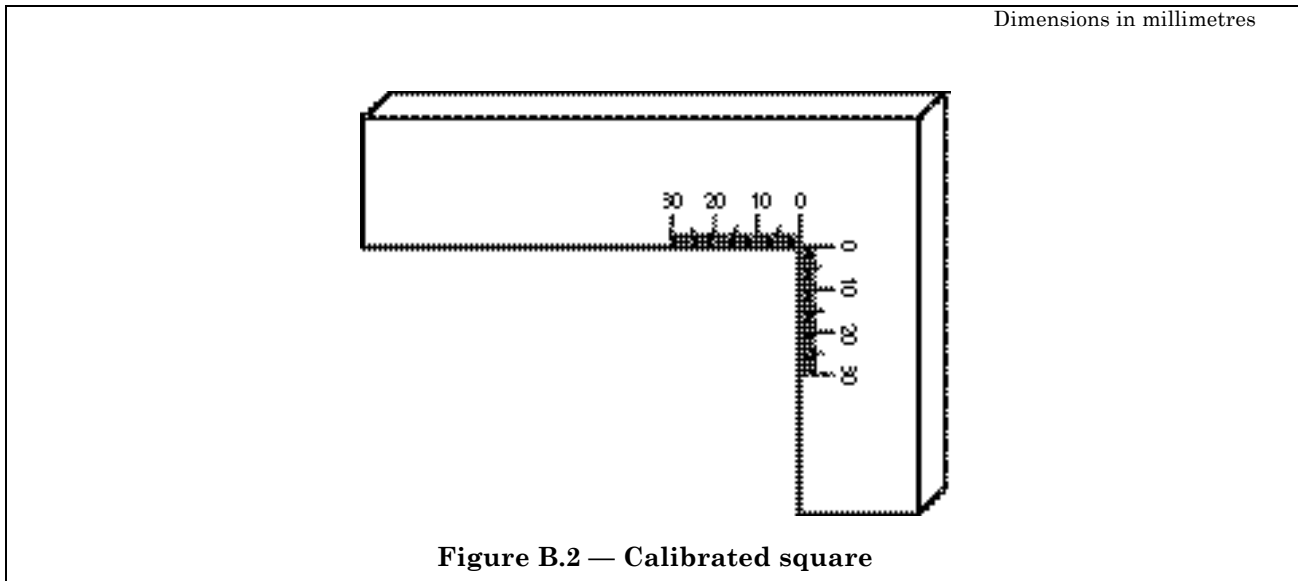

### B.5.2 Procedure

Using the calibrated square (B.5.1.1), take measurements at four positions on the paving flag, one on each side. Calculate and record the average vertical and horizontal dimensions of the chamfer to the nearest whole number of millimetres.

Measure the draw and record its dimensions to a whole number of millimetres.

### B.6 Thickness of facing layer

Take a paving flag that has been broken in the bending test. Using measuring equipment with a precision of 0.5 mm, measure the thickness of the facing layer on the broken face at the point where, by visual inspection, the value is at its lowest. Do not measure the thickness of the facing layer on a chamfer and ignore isolated particles of aggregate protruding into it.

Record the measurement to the nearest millimetre.

### B.7 Test report

The test report shall include all the measurements taken (see also clause 8).

## Annex C (normative)

### Sampling and testing of a consignment in case of dispute

#### C.1 General

In the event of a dispute regarding the quality of a consignment of paving flags, the procedure specified in this annex shall be followed. The properties to be tested shall be restricted to those that are in dispute.

The properties to be tested shall normally be restricted to those specified in Table C.1.

The test for visual properties shall be carried out prior to the tests for any other properties. The purchaser and the manufacturer shall agree a location for the test and they shall perform the test together at that location.

NOTE 1 The location used for visual testing is normally the site or the factory.

With the exception of the test for visual properties, all tests shall be carried out in a laboratory agreed by both the purchaser and the manufacturer. The purchaser and the manufacturer shall both be given the opportunity to witness the sampling and testing.

NOTE 2 The manufacturer's test equipment may be used to carry out the tests.

## C.2 Sampling and testing

The number of paving flags to be sampled, and the tests to be made on them, shall be as specified in Table C.1 or Table C.2 according to the property to be tested. The specified number of paving flags to be sampled shall be taken from each batch of up to 1000 paving flags in the whole consignment. The paving flags used for testing shall be selected as being representative of the batch and shall be evenly distributed through the batch.

**Table C.1 — Sampling and testing plan**

Property	Requirement specified in	Test method in accordance with	No. of paving flags
Shape and dimensions	5.2	Annex B <sup>a</sup>	3 <sup>b</sup>
Bending strength	5.3.3	Annex E	3
Appearance	5.4.1	Annex H	8 <sup>b</sup>
<sup>a</sup> B.6 applies only to paving flags with a facing layer. <sup>b</sup> These paving flags may be used for subsequent tests.			

**Table C.2 — Sampling and testing plan for additional properties**

Property	Requirement specified in	Test method in accordance with	No. of paving flags
Weathering resistance	5.3.2	Annex D	3
Abrasion resistance	5.3.4	Annex F	3
Slip/skid resistance	5.3.5	Annex G	4

## Annex D (normative)

### Method for determining weathering resistance

#### D.1 Principle

A test specimen is preconditioned and then subjected to 28 freeze/thaw cycles while the surface is covered with a 3 % NaCl solution. The material that has scaled off is collected and weighed and the result expressed as a mass per unit area of surface.

#### D.2 Materials

**D.2.1 Potable water.**

**D.2.2 Freezing medium,** consisting of a mass fraction of 97 % potable water and a mass fraction of 3 % NaCl.

**D.2.3 Adhesive,** resistant to the environmental conditions used in the test, for gluing the rubber sheet to the concrete specimen.

NOTE Contact adhesive has proved to be a suitable adhesive for use in this procedure.

**D.2.4 Silicon rubber,** or other sealant, to provide a seal between the specimen and the rubber sheet and to fill in any chamfer around the perimeter of the specimen.

### D.3 Apparatus

**D.3.1** *Saw*, for cutting the concrete specimen.

**D.3.2** *Climate chamber*, with a temperature of  $(20 \pm 2) ^\circ\text{C}$  and a relative humidity of  $(65 \pm 10) \%$ . In the climate chamber the evaporation from a free water surface shall be  $(200 \pm 100) \text{ g/m}^2$  in  $(240 \pm 5) \text{ min}$ . The evaporation shall be measured from a bowl with a depth of approximately 40 mm and a cross-section area of  $(22500 \pm 2500) \text{ mm}^2$ . The bowl shall be filled up to  $(10 \pm 1) \text{ mm}$  from the brim.

**D.3.3** *Rubber sheet*,  $(3 \pm 0.5) \text{ mm}$  thick, resistant to the salt solution used and elastic down to a temperature of  $-20 ^\circ\text{C}$ .

**D.3.4** *Vernier calliper*, with an accuracy of  $\pm 0.1 \text{ mm}$ .

**D.3.5** *Thermal insulation material*, consisting of expanded polystyrene  $(20 \pm 1) \text{ mm}$  thick with a thermal conductivity between  $0.035 \text{ W/m}\cdot\text{K}$  and  $0.04 \text{ W/m}\cdot\text{K}$  or other equivalent insulation.

**D.3.6** *Polyethylene sheet*, 0.1 mm to 0.2 mm thick.

**D.3.7** *Freezing chamber*, incorporating a time-controlled refrigerating and heating system with a capacity and air circulation such that the time-temperature curve presented in Figure D.3 can be followed.

**D.3.8** *Thermocouples*, or an equivalent temperature-measuring device, for measuring the temperature in the freezing medium on the test surface to an accuracy within  $\pm 0.5 ^\circ\text{C}$ .

**D.3.9** *Vessel*, for collecting scaled material. The vessel shall be suitable for use up to  $120 ^\circ\text{C}$  and shall withstand sodium chloride attack.

**D.3.10** *Spray bottle*, containing potable water for washing off scaled material and washing salt out of scaled material.

**D.3.11** *Paint brush*, 20 mm to 30 mm wide, with bristles cut down to about 20 mm long, for brushing off scaled material.

**D.3.12** *Filter paper*, for collecting scaled material.

**D.3.13** *Drying cabinet*, with a temperature of  $(105 \pm 5) ^\circ\text{C}$ .

**D.3.14** *Balance*, with an accuracy of  $\pm 0.05 \text{ g}$ .

### D.4 Preparation of test specimen

The test specimen shall incorporate an upper face area greater than  $7500 \text{ mm}^2$  but less than  $25000 \text{ mm}^2$ , which shall be the test surface and shall have a maximum thickness of 103 mm. If the specimen has to be taken from a paving flag to meet this requirement, it shall be sawn (**D.3.1**), when the paving flag is at least 20 days old.

When the test specimens are at least 28 days old, flashings and loose material shall be removed.

The specimens shall be placed in the climate chamber (**D.3.2**). There shall be a minimum air space between the specimens of 50 mm. The specimens shall be cured for  $(168 \pm 5) \text{ h}$ .

The rubber sheet (**D.3.3**) shall be glued to all surfaces of the specimen except the test surface, using the adhesive (**D.2.3**). Silicon rubber or other sealant (**D.2.4**) shall be used to fill in the chamfer around the perimeter of the specimen and to provide a seal around the test surface in the corner between the concrete and the rubber sheet to prevent water penetration between the specimen and rubber. The edge of the rubber sheet shall reach  $(20 \pm 2) \text{ mm}$  above the test surface.

NOTE The adhesive should normally be spread on the concrete surfaces as well as on the rubber surfaces. The manner of gluing the rubber sheet illustrated in Figure D.1 has proved suitable.

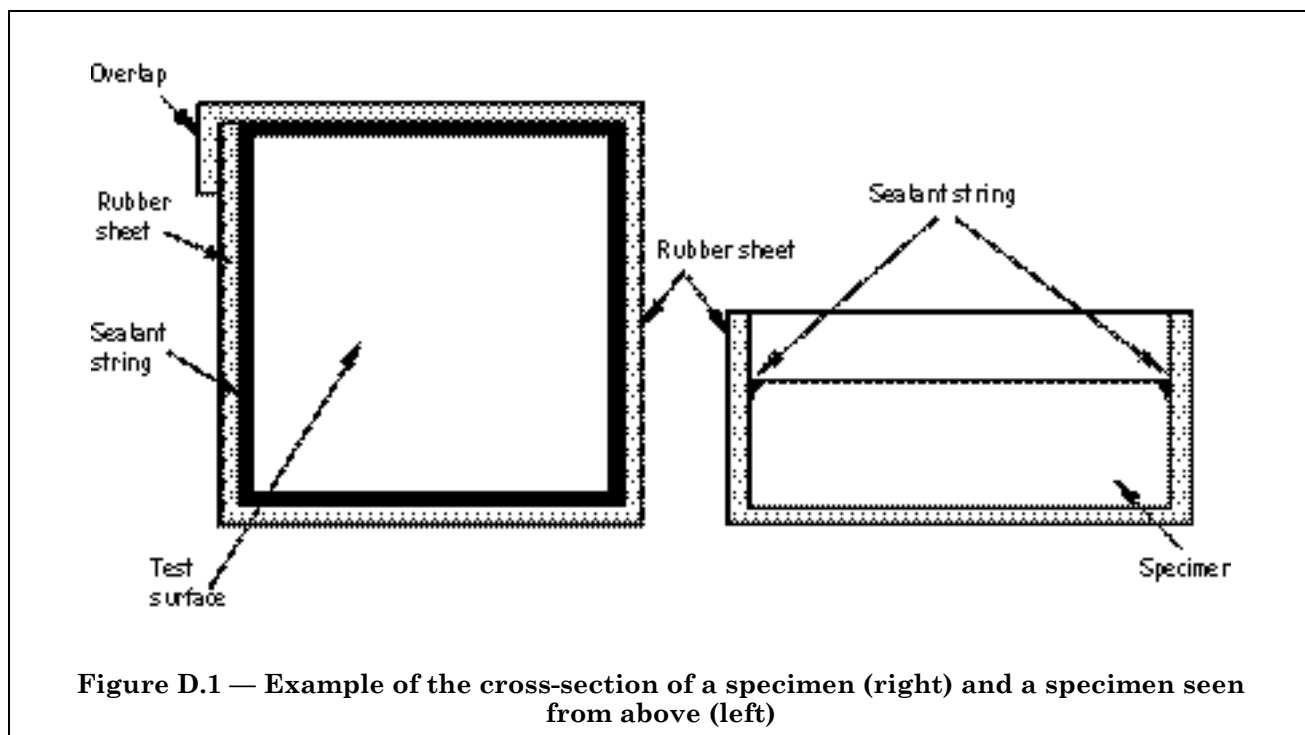

Using the vernier calliper (D.3.4), the tested area  $A$  shall be established from the mean of three measurements of its length and width to the nearest millimetre. After curing in the climate chamber, potable water (D.2.1) with a temperature of  $(20 \pm 2) ^\circ\text{C}$  shall be poured on the test surface to a depth of  $(5 \pm 2)$  mm. This shall be maintained for  $(72 \pm 2)$  h at  $(20 \pm 2) ^\circ\text{C}$ .

NOTE 1 This may be used to assess the effectiveness of the seal between the specimen and the rubber sheet.

Before the freeze/thaw cycling, all surfaces of the specimen except the test surface shall be covered with thermal insulation material (D.3.5).

NOTE 2 The thermal insulation of the surfaces may be carried out during curing.

Between 15 min and 30 min before the specimens are placed in the freezing chamber, the water on the test surface shall be replaced with a  $(5 \pm 2)$  mm layer, measured from the top surface of the specimen, of 3 % NaCl in potable water (D.2.2). This shall be prevented from evaporating by applying a horizontal polyethylene sheet (D.3.6) as shown in Figure D.2. The polyethylene sheet shall remain as flat as possible throughout the test and shall not come into contact with the freezing medium.



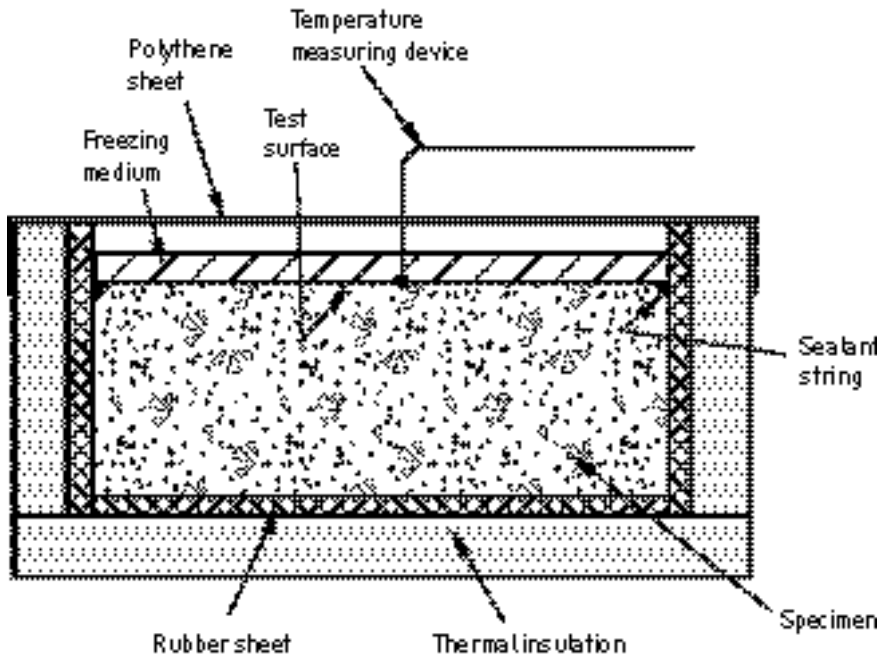
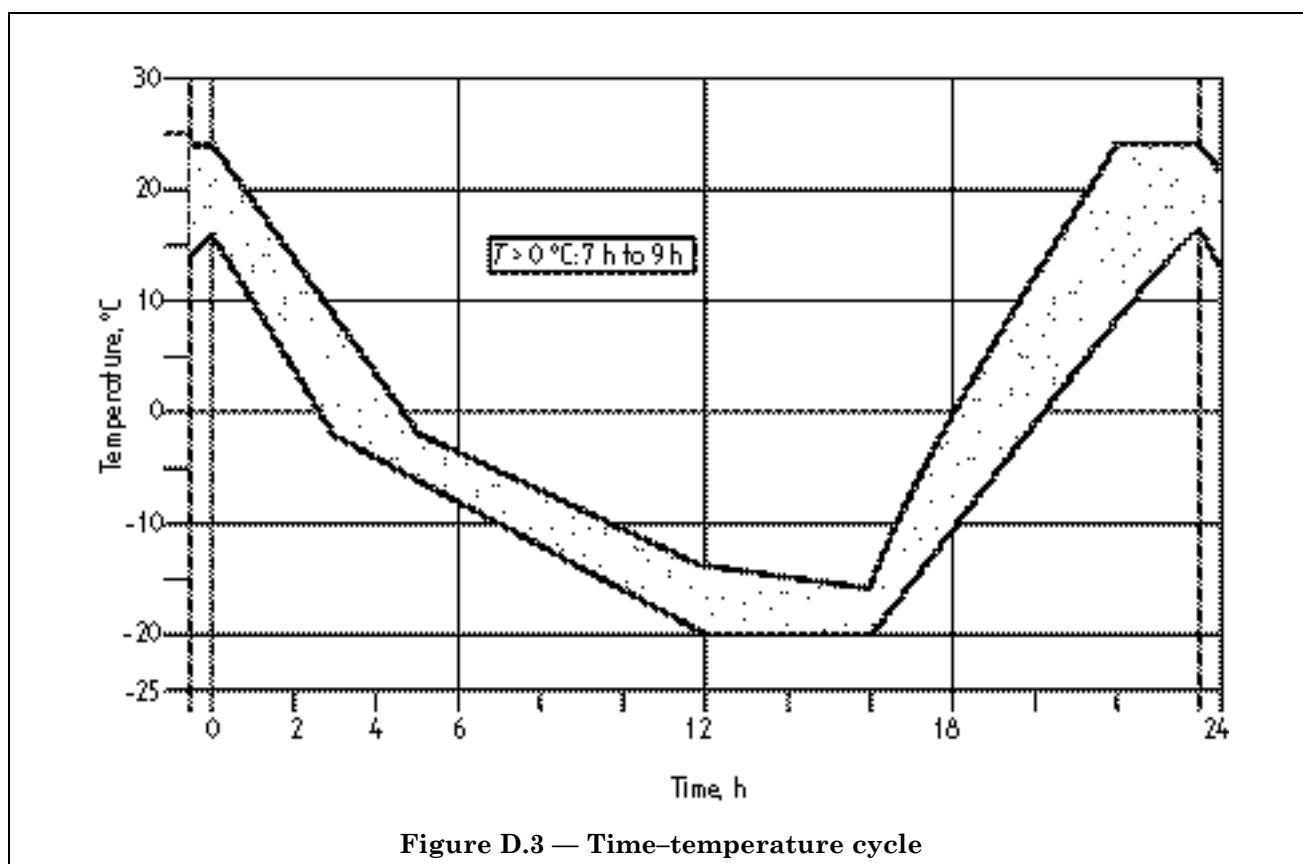

Figure D.2 — Principle of set-up for the freeze/thaw test

#### D.5 Procedure

Place the specimens in the freezing chamber (D.3.7) such that the test surface does not deviate from a horizontal plane by more than 3 mm/m in any direction and such that the specimens are subjected to repeated freezing and thawing.

During the test the time-temperature cycle in the freezing medium at the centre of the surface of all specimens shall fall within the shaded area shown in Figure D.3. Furthermore the temperature shall exceed 0 °C during each cycle for at least 7 h but not more than 9 h.



NOTE The break points specifying the shaded area are given in Table D.1.

**Table D.1 — Co-ordinates of break points**

Upper limit		Lower limit	
Time	Temperature	Time	Temperature
h	°C	h	°C
0	24	0	16
5	-2	3	-4
12	-14	12	-20
16	-16	16	-20
18	0	20	0
22	24	24	16

Using the thermocouples (D.3.8), continuously record the temperature in the freezing medium at the centre of the test surface for at least one specimen, which shall be located in a representative position in the freezing chamber. Record the air temperature in the freezer during the test. Start the timing of the first cycle of the test on a specimen within  $(0 \pm 30)$  min of it being placed in the freezing chamber.

If a cycle has to be interrupted, the specimen shall be kept in the frozen state between  $-16^\circ\text{C}$  and  $-20^\circ\text{C}$ . If an interruption continues for more than 3 days the test shall be abandoned.

To obtain the correct temperature cycle for all the specimens, good air circulation shall be ensured in the freezing chamber. If only a few specimens are to be tested, the empty places in the freezer shall be filled with dummies, unless it has been demonstrated that the correct temperature cycle is achieved without them.

After 7 cycles and 14 cycles, during the thaw period further solution of 3 % NaCl in potable water shall be added if necessary in order to keep a  $(5 \pm 2)$  mm layer on the surface of the samples.

After 28 cycles carry out the following procedure for each specimen.

- a) Collect material that has been scaled from the test surface by rinsing it into the vessel (D.3.9) using the spray bottle (D.3.10) and brushing it into the vessel using the paint brush (D.3.11) until no further scaled material is removed.
- b) Pour the liquid and scaled material in the vessel carefully through a filter paper (D.3.12). Wash the material collected in the filter paper with a minimum of 1 l of potable water to remove any remaining NaCl.
- c) Dry the filter paper and collected material in the drying cabinet (D.3.13) for at least 24 h at  $(105 \pm 5)$  °C.
- d) Using the balance (D.3.14), determine to  $\pm 0.2$  g the dry mass of the scaled material, making due allowance for the filter paper.

#### D.6 Calculation of test result

Calculate the mass loss per unit area,  $m$ , of the specimen in kilograms per square metre ( $\text{kg/m}^2$ ) from the following equation:

$$m = \frac{M}{A}$$

where

- $M$  is the mass of the total quantity of material scaled after 28 cycles, in milligrams (mg);  
 $A$  is the area of the test surface, in square millimetres ( $\text{mm}^2$ ).

#### D.7 Test report

The test report shall include the following information (see also clause 8):

- a) mass of total quantity of material scaled after 28 cycles, in milligrams (mg);
- b) area of the test surface, in square millimetres ( $\text{mm}^2$ );
- c) mass loss per unit area of the specimen.

## Annex E (normative)

### Method for measuring bending strength

#### E.1 Apparatus

**E.1.1** *Transverse testing machine*, with a scale having an accuracy of  $\pm 3\%$  over the range of the anticipated test loads and capable of increasing the load at specified rates. It shall be equipped with a device that can induce 3-point bending into the specimen without torsion (see Figure E.1). The load-inducing bar shall be equidistant between the supports. The length of the supports and the load-inducing bar shall be at least equal to the width of the sample to be tested. The upper and lower bearers shall be parallel and rigid, and round, or rounded to a radius of  $(20 \pm 1)$  mm.

**E.1.2** *Packing pieces* (optional), with a width not exceeding 25 mm. Their thickness shall be  $(4 \pm 1)$  mm and they shall be at least 10 mm longer than the width of the specimen.

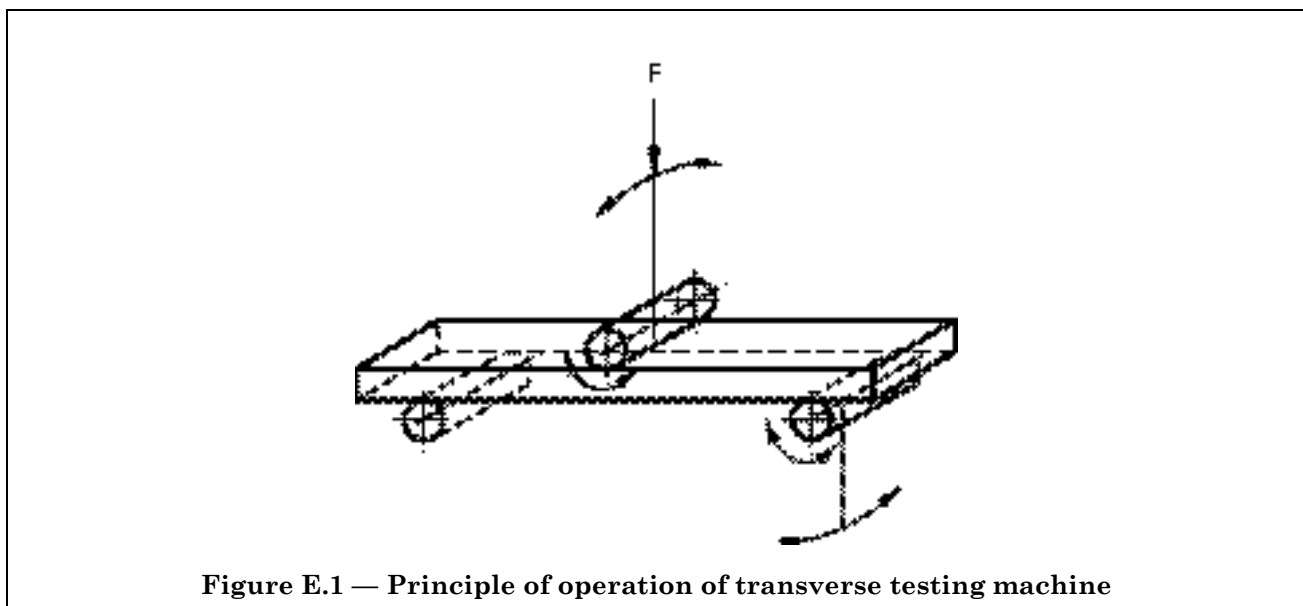

Figure E.1 — Principle of operation of transverse testing machine

#### E.2 Preparation of test specimen

Use whole paving flags when their plan shape includes at least two parallel straight edges. In other cases use sawn specimens with the largest possible plan area which includes two parallel straight edges.

If necessary remove any burrs, high spots, etc.

If a face is rough, textured or curved, prepare it by grinding or capping.

Immerse the specimen in water at  $(20 \pm 5)$  °C for  $(24 \pm 3)$  h, remove, wipe dry and test immediately.

**E.3 Procedure**

The distance between the supports and the edge of the specimen shall be 25 mm unless this results in a span of less than three times the thickness of the specimen. If the span is less than three times the thickness, the distance between the bearers and the edge of the specimen shall be reduced to half the thickness of the specimen. The actual span shall be measured and recorded.

Place the specimen symmetrically on the bearers of the transverse testing machine (E.1.1), with its upper face uppermost and with its shorter side parallel to the supporting bearers.

Depending on the surface profile of the specimen, any one of the following shall be used at the discretion of the manufacturer:

- no packing pieces;
- packing pieces (E.1.2);
- capping or grinding.

Apply the load without shock and increase the load uniformly so that the required load is reached within  $(45 \pm 15)$  s. Record the failure load,  $P$ , to the nearest 100 N.

**E.4 Calculation of test result**

Calculate the strength,  $T$ , in megapascals (MPa) of the specimen tested from the following equation:

$$T = \frac{3 \times P \times L}{2 \times b \times t^2}$$

where

- $P$  is the failure load, in newtons (N);
- $L$  is the distance apart of the supports, in millimetres (mm);
- $b$  is the width of the specimen at the failure plane, in millimetres (mm);
- $t$  is the thickness of the specimen at the failure plane, in millimetres (mm).

Record the individual result,  $T$ , in megapascals (MPa) and the failure load,  $P$ , in kilonewtons (kN).

**E.5 Test report**

The test report shall include the following information (see also clause 8):

- a) failure load of each paving flag, to the nearest 0.1 kN;
- b) strength of each paving flag, to the nearest 0.1 MPa;
- c) mean strength of the paving flags tested.

## Annex F (normative)

### Method for measuring abrasion resistance

#### F.1 Principle

The test is carried out by abrading the upper face of a paving flag with an abrasive material under controlled conditions.

#### F.2 Materials

**F.2.1 Abrasive material**, comprising fused alumina with a grit size of F80 in accordance with BS ISO 8486-1:1996. A single quantity of abrasive material shall be used not more than three times. The moisture content of the abrasive material shall not exceed 1.0 %.

#### F.3 Apparatus

**F.3.1 Wearing machine** (see Figure F.1), comprising a wide abrasion wheel (**F.3.2**), a mobile clamping trolley (**F.3.3**), a storage hopper (**F.3.4**), a flow guidance hopper (**F.3.5**), and a counterweight.

**F.3.2 Wide abrasion wheel**, which shall be made of steel E360 in accordance with BS EN 10083-2:1991. The hardness of the steel shall be between 203 HB and 245 HB. The diameter of the wheel shall be  $(200 \pm 1)$  mm and its width shall be  $(70 \pm 1)$  mm. It shall be driven to rotate 75 revolutions in  $(60 \pm 3)$  s.

**F.3.3 Mobile clamping trolley**, mounted on bearings and forced by a counterweight to move forwards to the wheel.

**F.3.4 Storage hopper**, which shall contain the abrasive material and shall feed into the flow guidance hopper. It shall have one or two control valves to regulate the output of the abrasive material. When two valves are used, one shall be used to regulate the rate of flow and can be permanently set while the other shall be used to turn the flow on and off.

**F.3.5 Flow guidance hopper**, which shall be either cylindrical or rectangular and shall have a slotted outlet (see Figure F.2). The length of the slot shall be  $(45 \pm 1)$  mm and the width shall be  $(4 \pm 1)$  mm. The body of the flow guidance hopper shall be at least 10 mm bigger than the slot in all directions [see Figure F.2a)], unless the hopper is rectangular, with at least one of the sides inclined down to the long side of the slot, in which case there shall be no dimensional limitations [see Figure F.2b)].

The distance of the fall between the slot and the axle of the wide abrasion wheel shall be  $(100 \pm 5)$  mm and the flow of the abrasive shall be 1 mm to 5 mm behind the leading edge of the wheel (see Figure F.3 or Figure F.4).

The flow of the abrasive material from the flow guidance hopper shall be at a minimum rate of 2.5 l/min onto the wide abrasion wheel. The flow of abrasive shall be constant and the minimum level of the abrasive material in the flow guidance hopper shall be 25 mm (see Figure F.3 or Figure F.4).

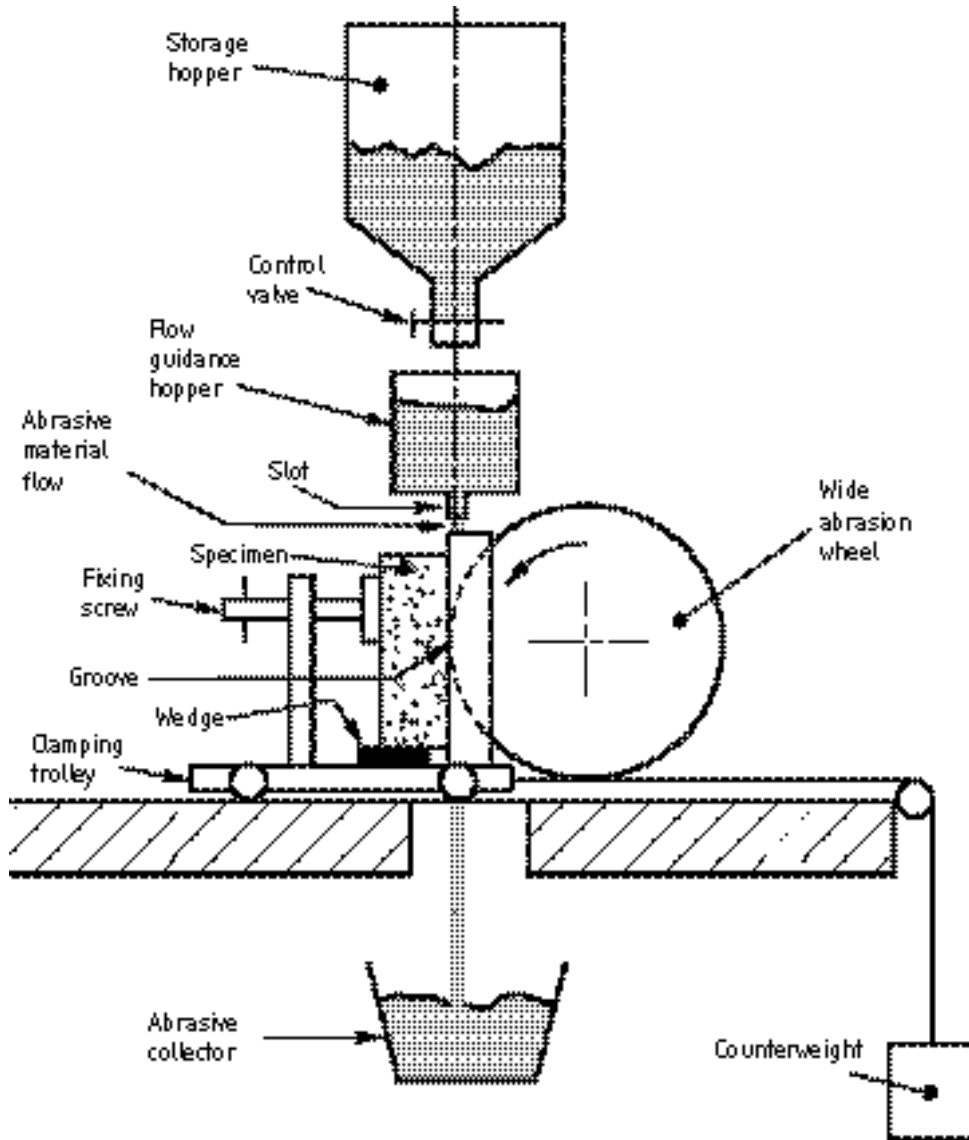
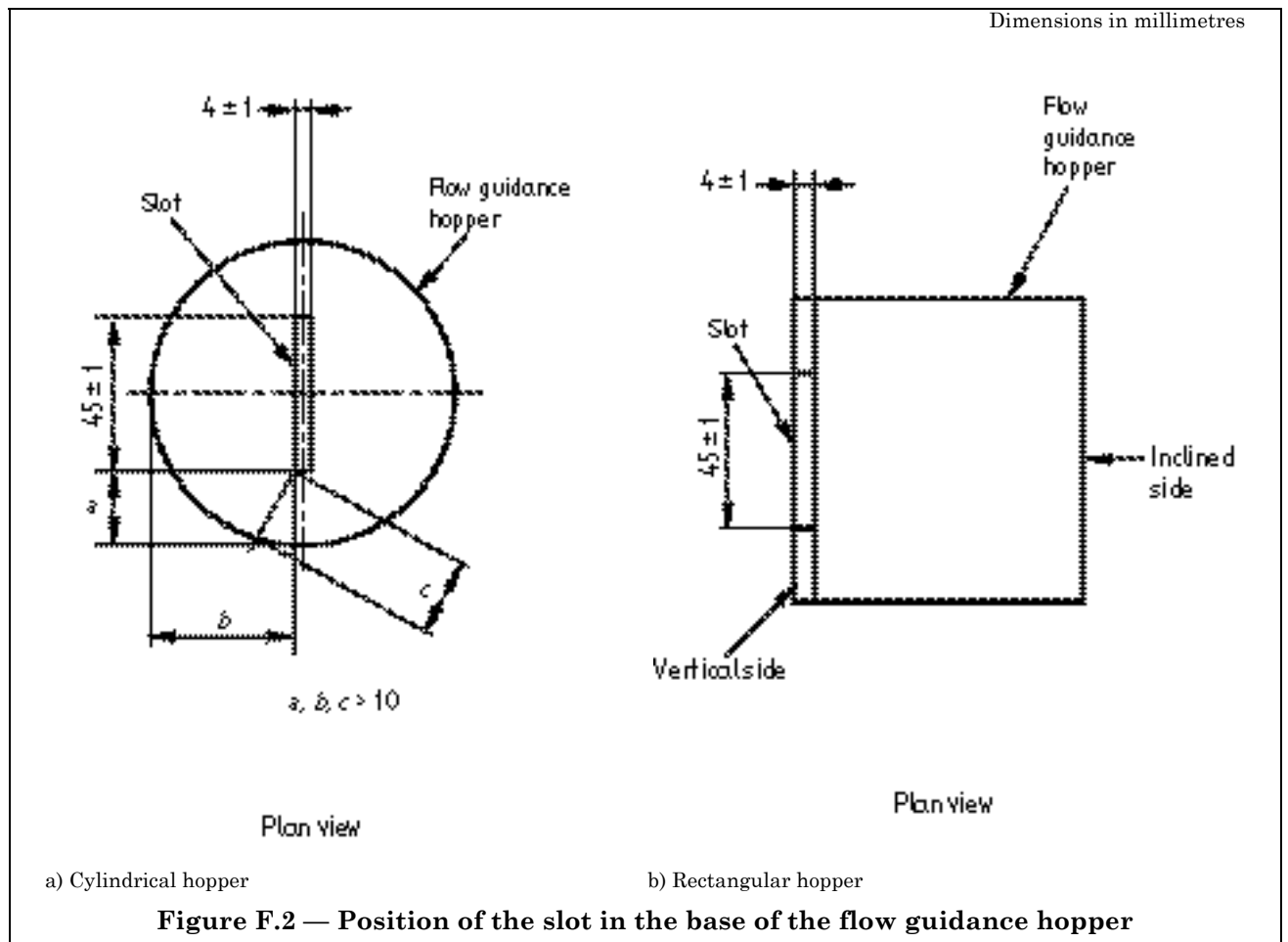

Figure F.1 — Principle of operation of wearing machine





Dimensions in millimetres

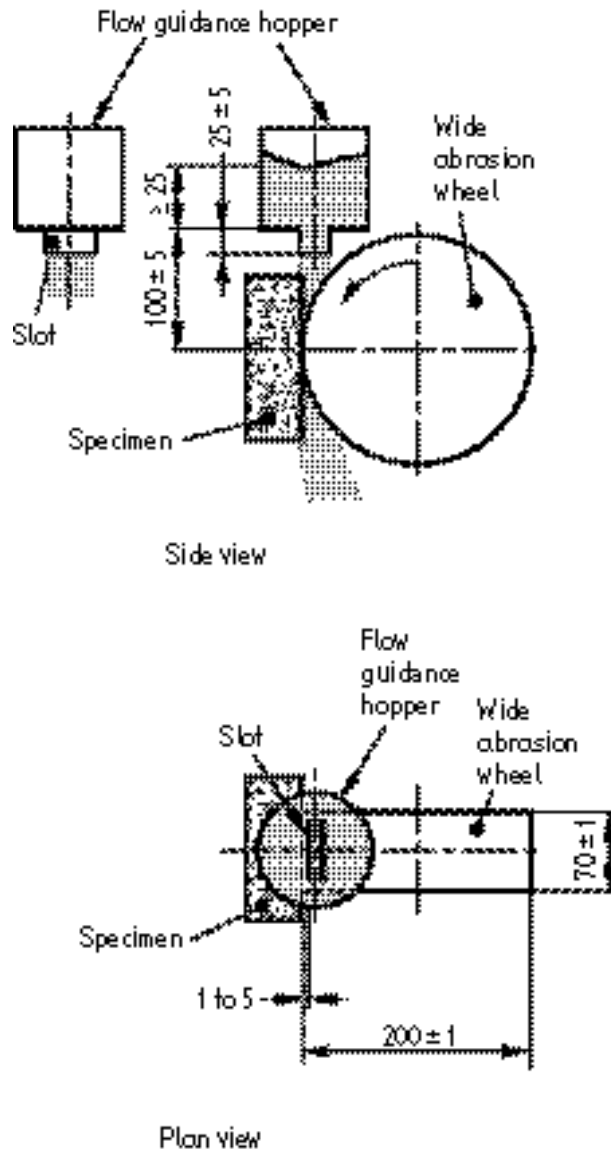
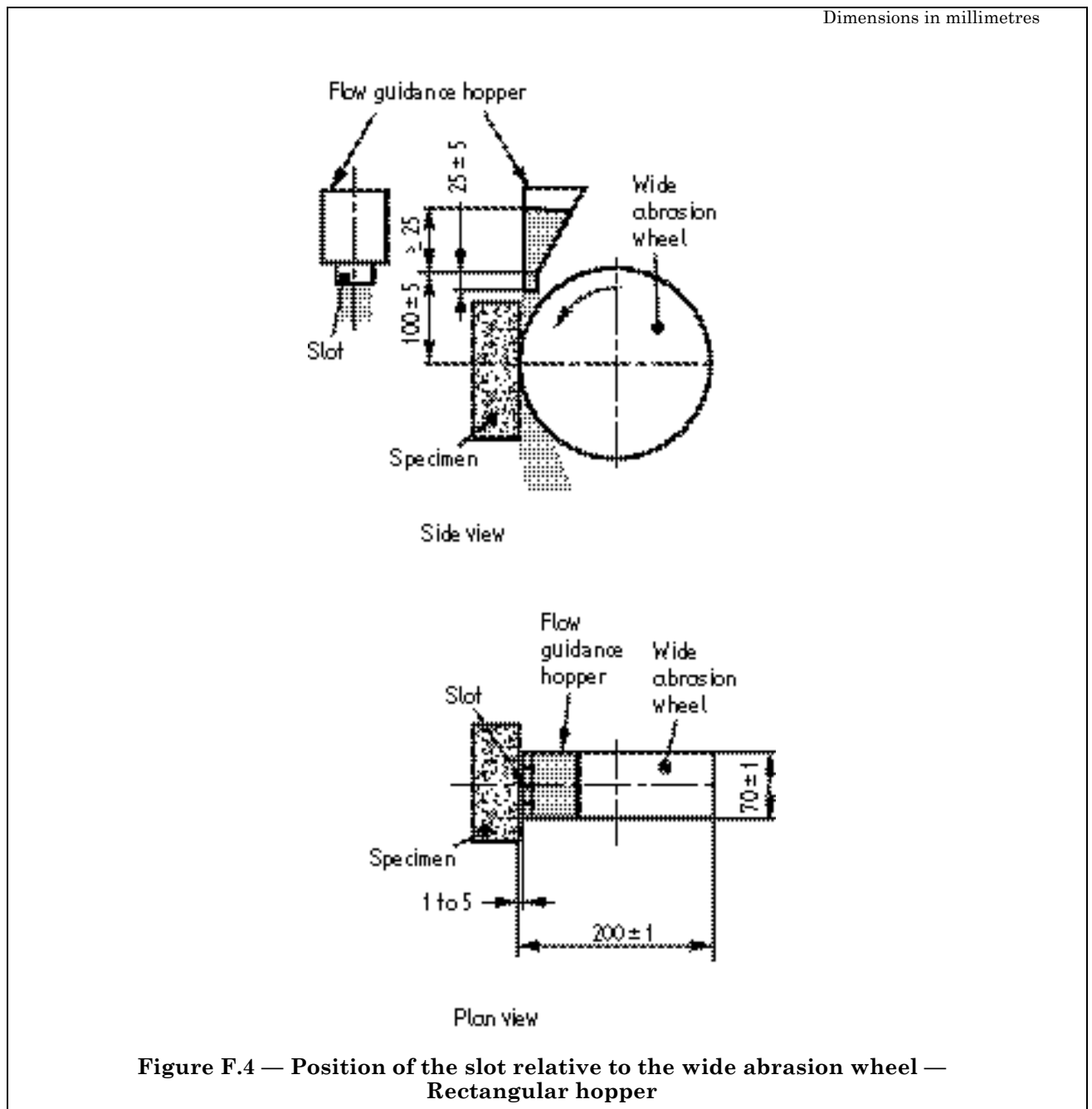

Figure F.3 — Position of the slot relative to the wide abrasion wheel — Cylindrical hopper



**F.3.6** *Stiff brush*, for cleaning the test surface.

**F.3.7** *Surface dye*, to facilitate the measuring of the groove.

NOTE A marker pen has proved to be a suitable tool for dyeing the surface.

**F.3.8** *Abrasive collector*, to collect abrasive material falling from the wheel.

**F.3.9** *Pencil*, with a lead diameter of 0.5 mm and a hardness of 6H or 7H.

**F.3.10** *Steel ruler*, for measuring the abrasion groove.

**F.3.11** *Digital calliper*, for measuring the abrasion groove.

#### F.4 Calibration

The apparatus shall be calibrated after grinding 400 grooves or every 2 months, whichever is the lesser, and every time there is a new operator, a new batch of abrasive material, or a new abrasion wheel.

The flow rate of the abrasive material shall be verified by pouring the material from a height of approximately 100 mm into a pre-weighed rigid container with a smooth rim, of height  $(90 \pm 10)$  mm and of approximately 1 l volume when filled to the top. As the container fills, the pouring height shall be raised to maintain approximately the 100 mm fall. When the container is filled, the top shall be struck off level and the container weighed to determine the mass of abrasive material for a known volume, i.e. the density. Abrasive material shall be run through the wearing machine for  $(60 \pm 1)$  s and collected below the abrasion wheel in a pre-weighed container of at least 3 l capacity. The filled container shall be weighed and the rate of flow of abrasive material shall be determined.

The apparatus shall be calibrated, using the procedure in **F.6**, against a reference sample of “Boulonnaise Marble” with the following properties:

- “Lunel demi-clair”;
- a thickness greater than or equal to 50 mm;
- cut perpendicular to the bed direction;
- two faces ground with a diamond grit size of 100/200;
- a roughness, when measured with a stylus measuring instrument in accordance with BS EN ISO 4288, of  $R_a = (1.6 \pm 0.4)$   $\mu\text{m}$ .

The counterweight shall be adjusted so that after 75 revolutions of the wheel in  $(60 \pm 3)$  s the length of the groove produced is  $(20.0 \pm 0.5)$  mm.

The clamping trolley/counterweight assembly shall be checked for undue friction.

The groove shall be measured to the nearest 0.1 mm using the procedure in **F.7**, and the three results shall be averaged to give the calibration value.

At every calibration of the apparatus, the squareness of the sample supports shall be checked and corrected if necessary.

The groove on the reference sample shall be rectangular with the difference between the measured length of the groove at either side not exceeding 0.5 mm. If necessary check that:

- a) the sample has been held square to the wheel;
- b) the clamping trolley and the slot from the flow guidance hopper are parallel to the wheel axle;
- c) the flow of abrasive is even across the slot;
- d) the friction in the trolley/counterweight assembly does not prevent smooth operation.

#### F.5 Preparation of specimen

The test specimen shall be a whole paving flag or a cut piece measuring at least 100 mm  $\times$  70 mm incorporating the upper face of the paving flag. The test piece shall be clean and dry.

The upper face, which shall be tested, shall be flat within a tolerance of  $\pm 1$  mm measured in accordance with **B.4** in two perpendicular directions, but over 100 mm.

If the upper face has a rough texture or is outside this tolerance it shall be lightly ground to produce a smooth flat surface within this tolerance.

Immediately before testing, the surface to be tested shall be cleaned with a stiff brush (**F.3.6**) and covered with a surface dye (**F.3.7**) to facilitate measuring the groove.

### F.6 Procedure

Fill the storage hopper with dry abrasive material (F.2.1). Move the clamping trolley away from the wide abrasion wheel. Position the test specimen on it such that the groove produced is at least 15 mm from any edge of the specimen, and fix the specimen on a wedge to let the flow of abrasive material pass under it. Place the abrasive collector (F.3.8) beneath the wide abrasion wheel.

Bring the test specimen into contact with the wide abrasion wheel, open the control valve and simultaneously start the motor so that the wide abrasion wheel achieves 75 revolutions in  $(60 \pm 3)$  s. Visually check the regularity of the flow of the abrasive material during the test. After 75 revolutions of the wheel, stop the flow of abrasive material and the wheel.

### F.7 Measuring the groove

Using the pencil (F.3.9) and ruler (F.3.10), draw the external longitudinal limits ( $l_1$  and  $l_2$ ) of the groove (see Figure F.5).

Draw a line (A B) in the middle of the groove perpendicular to the centreline of the groove. Position the square tips of the digital calliper (F.3.11) on the points A and B to the inside edge of the longitudinal limits ( $l_1$  and  $l_2$ ) of the groove, and measure and record the dimension of the groove to the nearest 0.1 mm.

For calibration purposes, repeat the measurement ( $10 \pm 1$ ) mm from the ends of the groove (C D) to give three readings.

NOTE Some surface dye can be removed above the groove by action of the abrasive. This should be ignored in producing line  $l_1$ , which should be drawn where the sample surface is abraded.

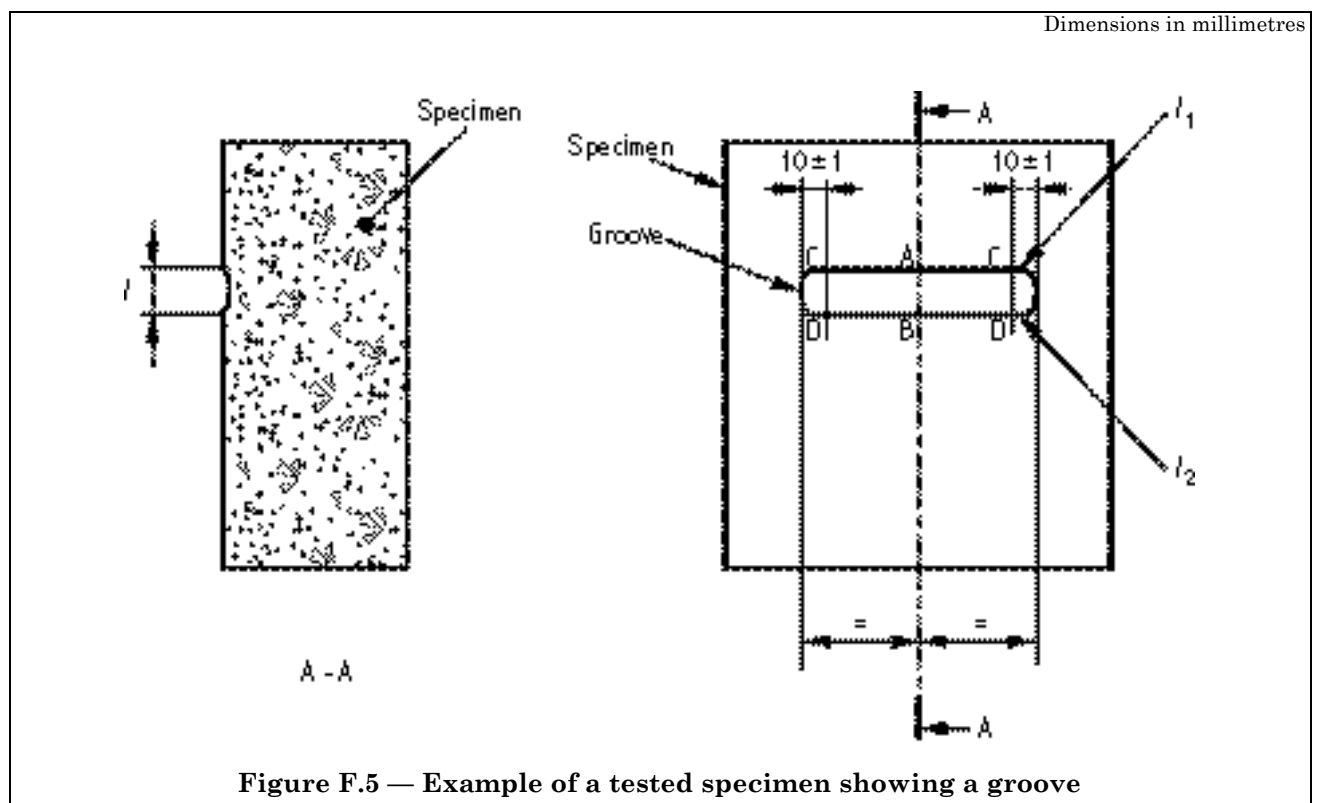

Figure F.5 — Example of a tested specimen showing a groove

### F.8 Calculation of test result

The test result shall be the dimension of the groove, corrected by a calibration factor that shall be the arithmetic difference between 20.0 and the recorded calibration value, and then rounded to the nearest 0.5 mm.

NOTE As an example of a test result, if the calibration value is 19.6 mm and the dimension of the groove is 22.5 mm, the result is  $22.5 + (20.0 - 19.6) = 22.9$  mm, rounded to 23.0 mm.

### F.9 Test report

The test report shall include the lengths of the grooves (see also clause 8).

## Annex G (normative)

### Method for determining the slip/skid resistance value

#### G.1 Principle

The paving flag is tested to determine both the unpolished skid resistance value (USRV) and the polished pendulum test value (PPTV). The lower of the two values determined is taken to be the slip/skid resistance value.

#### G.2 Determination of the unpolished skid resistance value (USRV)

##### G.2.1 Principle

The measurement of the USRV of a specimen is made using a pendulum friction tester passing over the surface of the specimen.

The USRV is not measured if the surface of the paving flag contains ridges, grooves or other surface features that prevent testing by the pendulum friction tester, or if the paving flag is too small to provide a test area (see G.2.3).

##### G.2.2 Apparatus

**G.2.2.1 Pendulum friction tester**, with a C scale, conforming to BS 812-114:1989. This shall be calibrated at least annually and validated as specified in BS 7932:1998, 8.1. The rubber slider shall be 76 mm wide and shall conform to BS 812-114.

##### G.2.3 Preparation of test specimens

Obtain a sample of four paving flags of the same family (see A.1) using the sampling procedure specified in BS 7932:1998, Annex A. Cut a test specimen (typically 200 mm × 100 mm) from each paving flag which permits a test area of 136 mm × 86 mm.

Place the test specimens in water at  $(20 \pm 2)$  °C until they are tested.

##### G.2.4 Procedure

Keep the pendulum friction tester (G.2.2.1) and rubber slider in a room at a temperature of  $(20 \pm 2)$  °C for at least 2 h before commencing testing.

Place the pendulum friction tester upon a firm, level surface and adjust the levelling screws so that the pendulum support column is vertical. Raise the axis of suspension of the pendulum so that the arm swings freely and adjust the friction in the pointer mechanism so that when the pendulum arm and pointer are released from the right-hand horizontal position the pointer comes to rest at zero position on the test scale.

Before using a new rubber slider, condition it using the method specified in BS 812-114:1989. Discard any rubber slider that fails to conform to BS 812-114:1989.

Carry out the pendulum test on each of the four specimens using the following procedure, using the rubber slider over a 126 mm swept length and with readings taken on the C scale.

Immediately prior to testing with the pendulum friction tester, remove the specimen from the water. Locate the test specimen with its longer dimension lying in the track of the pendulum, and centrally with respect to the rubber slider and to the axis of the suspension of the pendulum. Ensure that the track of the rubber slider is parallel to the long axis of the specimen across the sliding distance.

Adjust the height of the pendulum arm such that in traversing the specimen, the rubber slider is in contact with it over the whole width of the slider and over the swept length of 126 mm. Wet the surfaces of the specimen and the rubber slider with a copious supply of clean water, being careful not to disturb the slider from its set position. Release the pendulum and pointer from the horizontal position, and catch the pendulum arm on its return swing. Record the position of the pointer on the scale.

Perform this operation five times, re-wetting the specimen each time. Record the mean of the last three readings.

Rotate the specimen through 180° and repeat the procedure.

Repeat the test on each of the remaining three specimens.

### **G.2.5 Calculation of the USRV**

Calculate the USRV of each specimen as the mean of the two recorded mean values measured in opposite directions to the nearest 1 unit on the C scale.

Calculate the USRV of the sample as the mean of the values obtained for the four specimens.

### **G.3 Determination of the polished pendulum test value (PPTV)**

#### **G.3.1 Principle**

The measurement of the PPTV of a specimen is made using a pendulum friction tester passing over the surface of the specimen after the specimen has been subjected to a polishing regime in a flat-bed polisher.

#### **G.3.2 Preparation of test specimens**

From the samples already tested for a USRV (G.2.4), prepare four specimens conforming to BS 7932:1998. Larger specimens, typically 200 mm × 100 mm, may be used using the wide rubber slider, long swing and C scale, provided that a correlation has been established.

#### **G.3.3 Procedure**

The test shall be carried out in accordance with BS 7932:1998.

#### **G.3.4 Calculation of the PPTV**

Calculate the PPTV of each specimen as the mean of the last three readings on that specimen.

Calculate the PPTV of the sample as the mean of the values obtained for the four specimens.

### **G.4 Test result**

The slip/skid resistance value shall be the lower of the USRV and the PPTV values.

### **G.5 Test report**

The test report shall include the following information (see also clause 8):

- a) the mean USRV of the specimens;
- b) the mean PPTV of the specimens;
- c) the slip/skid resistance value of the specimens;
- d) the number of this British Standard (BS 7263-1);
- e) any observations pertinent to the test made during testing, e.g. the surface texture of the specimens.

## **Annex H (normative)**

### **Method for verifying visual properties**

#### **H.1 Preparation of sample**

Each paving flag in the sample shall be examined for delamination. If any paving flag shows delamination, the procedure specified in A.3.3 shall be followed. The remaining paving flags shall then be laid out at floor level in a pattern approximating to a square.

#### **H.2 Procedure**

In natural daylight conditions an observer shall stand in turn at a distance of 2 m from each edge of the square and shall record any paving flag showing cracks or flaking.

The texture shall be compared with any manufacturer's reference samples supplied.

The visual properties shall be compared with any manufacturer's reference samples supplied.

**Annex I (normative)****Conformity assessment for bending strength**

If the mean strength of three paving flags tested is not lower than the mean value, and no individual strength is lower than the minimum value specified in Table 7 for the intended class, the corresponding production run shall be deemed to conform to this part of BS 7263.

If these conditions are not met, it shall be permissible to reclassify the corresponding production run to a class where the mean strength of the three paving flags tested is not lower than the mean value and no individual strength lower is than the minimum value specified in Table 7.

If the individual strength of any one of the paving flags tested is lower than the minimum value specified in Table 7 for class B1, the corresponding production run shall be deemed not to conform to this part of BS 7263.

**Annex J (informative)****Example of a typical production control system****J.1 Equipment inspection****J.1.1 Testing and measuring equipment**

Testing and measuring equipment should be inspected in accordance with Table J.1.

**Table J.1 — Testing and measuring equipment**

Subject	Aim	Method	Frequency
All testing and measuring equipment	To ensure functioning and accuracy	Where applicable calibrating against equipment which has been calibrated traceable to national standards and is used exclusively for this purpose except as indicated in the test method	On (re)installation, after major repair or once per year

**J.1.2 Storage and production equipment**

Storage and production equipment should be inspected in accordance with Table J.2.

**Table J.2 — Storage and production equipment**

Subject	Aim	Method	Frequency
Storage of materials	To ensure absence of contamination	Visual inspection or other appropriate method	On installation
			Weekly
Weighing or volumetric batching equipment	To ensure correct functioning	Visual inspection	Daily
	To ensure validity of manufacturer's declared accuracy	Calibrating against equipment which has been calibrated traceable to national standards and is used exclusively for this purpose	On (re)installation
			Weighing: twice a year
			Volumetric: twice a year
In case of doubt			
Mixers	To determine wear and ensure correct functioning	Visual inspection	Weekly
Moulds	To ensure cleanliness and determine condition	Visual inspection	Daily

**J.2 Materials inspection**

Materials should be inspected in accordance with Table J.3.

**Table J.3 — Materials inspection**

Subject	Aim	Method	Frequency
All materials	To ascertain that the consignment is as ordered and is from the correct source	Inspection of delivery ticket and/or label on the package showing conformity to the order	Each delivery

**J.3 Production process inspection**

Production processes should be inspected in accordance with Table J.4.

**Table J.4 — Production process inspection**

Subject	Aim	Method	Frequency
Mixture composition	To ensure conformity to intended composition (weight or volumetric batched)	Visual on weighing equipment	Daily
		Checking against production process documents	
	To ensure conformity to intended mixture values (only volumetric batched)	Fresh concrete analysis	Monthly
Concrete	Concrete mixing	Visual check	Daily for each mixer
Production	To ensure conformity to production control system	Checking actions against factory procedures	Daily



**J.4 Product inspection****J.4.1 Product testing**

Product testing (see A.3.2) should be carried out in accordance with Table J.5.

**Table J.5 — Product testing**

Subject	Aim	Method	Frequency <sup>a</sup>
Shape and dimensions	See 5.2	Annex B	Three paving flags per production line per production day
Bending strength	See 5.3.3, Table 7 and Annex I	Annex E	Three paving flags per strength family per production line per production day
Appearance	See 5.4.1	Visual check	Daily
		Annex H	In case of doubt (sample of 10 paving flags)

<sup>a</sup> This frequency does not include type testing (see A.2).

**J.4.2 Marking, storage and delivery**

Marking, storage and delivery should be inspected in accordance with Table J.6.

**Table J.6 — Marking, storage and delivery**

Subject	Aim	Method	Frequency
Marking	To ensure that the marking of the product conforms to clause 7	Visual check	Daily
Storage	To ensure segregation of non-conforming products	Visual check	Daily
Delivery	To ensure the correct delivery age, loading and loading documents	Visual check	Daily

---

## Bibliography

prEN 1339<sup>2)</sup>, *Concrete paving flags — Requirements and test methods.*

---

<sup>2)</sup> In preparation.

---

---

# BSI — British Standards Institution

BSI is the independent national body responsible for preparing British Standards. It presents the UK view on standards in Europe and at the international level. It is incorporated by Royal Charter.

## Revisions

British Standards are updated by amendment or revision. Users of British Standards should make sure that they possess the latest amendments or editions.

It is the constant aim of BSI to improve the quality of our products and services. We would be grateful if anyone finding an inaccuracy or ambiguity while using this British Standard would inform the Secretary of the technical committee responsible, the identity of which can be found on the inside front cover. Tel: 020 8996 9000. Fax: 020 8996 7400.

BSI offers members an individual updating service called PLUS which ensures that subscribers automatically receive the latest editions of standards.

## Buying standards

Orders for all BSI, international and foreign standards publications should be addressed to Customer Services. Tel: 020 8996 9001. Fax: 020 8996 7001. Standards are also available from the BSI website at <http://www.bsi-global.com>.

In response to orders for international standards, it is BSI policy to supply the BSI implementation of those that have been published as British Standards, unless otherwise requested.

## Information on standards

BSI provides a wide range of information on national, European and international standards through its Library and its Technical Help to Exporters Service. Various BSI electronic information services are also available which give details on all its products and services. Contact the Information Centre. Tel: 020 8996 7111. Fax: 020 8996 7048.

Subscribing members of BSI are kept up to date with standards developments and receive substantial discounts on the purchase price of standards. For details of these and other benefits contact Membership Administration. Tel: 020 8996 7002. Fax: 020 8996 7001. Further information about BSI is available on the BSI website at <http://www.bsi-global.com>.

## Copyright

Copyright subsists in all BSI publications. BSI also holds the copyright, in the UK, of the publications of the international standardization bodies. Except as permitted under the Copyright, Designs and Patents Act 1988 no extract may be reproduced, stored in a retrieval system or transmitted in any form or by any means – electronic, photocopying, recording or otherwise – without prior written permission from BSI.

This does not preclude the free use, in the course of implementing the standard, of necessary details such as symbols, and size, type or grade designations. If these details are to be used for any other purpose than implementation then the prior written permission of BSI must be obtained.

If permission is granted, the terms may include royalty payments or a licensing agreement. Details and advice can be obtained from the Copyright Manager. Tel: 020 8996 7070.