

---

British Standard Methods of test for  
**Soils for civil engineering purposes**  
Part 4. Compaction-related tests

---

Méthodes d'essai des sols pour le génie civil  
Partie 4. Essais de compactage

Bodenuntersuchung für Tiefbauzwecke  
Teil 4. Prüfung der Verdichtung

## Foreword

This Part of BS 1377 has been prepared under the direction of the Road Engineering Standards Policy Committee. It is a revision of clause 4 of BS 1377 : 1975 which is superseded by amendment. BS 1377 was first published in 1948 and first appeared in metric form in 1975. BS 1377 : 1975 is now being revised in nine separate Parts, the complete revision eventually comprising the following Parts.

- Part 1. General requirements and sample preparation
- Part 2. Classification tests
- Part 3. Chemical and electro-chemical tests
- Part 4. Compaction-related tests
- Part 5. Compressibility, permeability and durability tests
- Part 6. Consolidation and permeability tests in hydraulic cells and with pore pressure measurement
- Part 7. Shear strength tests (total stress)
- Part 8. Shear strength tests (effective stress)
- Part 9. In-situ tests

Reference should be made to Part 1 of BS 1377 for further information about each of the Parts.

The following methods of test, additional to those described in the 1975 standard, have been introduced.

Determination of the maximum and minimum densities of granular soils.

Determination of the moisture condition value.

Determination of the chalk crushing value.

In the dry density moisture relationship tests, and the California Bearing Ratio (CBR) test, sample preparation procedures have been set out in more detail than before, with explanatory flow diagrams.

It has been assumed in the drafting of this British Standard that the execution of its provisions is entrusted to appropriately qualified and experienced personnel, for whose guidance it has been prepared.

**Compliance with a British Standard does not of itself confer immunity from legal obligations.**

Amendment No. 1  
published and effective from 15 January 1995  
to BS 1377 : Part 4 : 1990

**Methods of test for soils for civil engineering purposes**  
**Part 4. Compaction-related tests**

**Revised text**

-----  
**Foreword**

In paragraph 1 delete the last sentence and substitute the following.

'BS 1377 : 1975 which has now been withdrawn is replaced by the following Parts of BS 1377 : 1990:'.

AMD 8259/January 1995

-----  
**Clause 3.7.2.2**

In line 2 delete '750 W' and substitute '800 W'. In line 3 delete '45 Hz' and substitute '60 Hz'.

AMD 8259/January 1995

-----  
**Clause 3.7.3.2 Material**

Delete the second sentence and substitute the following.

'The grading shall be such that at least 75 % passes the 600  $\mu\text{m}$  sieve and is retained on the 425  $\mu\text{m}$  test sieve and 100 % passes the 850  $\mu\text{m}$  test sieve and is retained on the 300  $\mu\text{m}$  test sieve. Dry and not previously used sand shall be used. This sand shall be sieved through a 600  $\mu\text{m}$  test sieve and the coarse fraction shall be discarded.'

AMD 8259/January 1995

-----  
**Clause 3.7.5.1.1**

In line 1, after 'baseplate' insert 'and extension'.

AMD 8259/January 1995



### Clause 3.7.5.1.8

In line 1, after 'baseplate' insert 'and extension'.

AMD 8259/January 1995

---

### Clause 3.7.6.1

In the definitions of  $m_1$  and  $m_2$  after 'baseplate' insert 'and extension'.

AMD 8259/January 1995

---

### Clause 5.2.1

In paragraph 5 of item (b) delete '\*at least 0.05 mm thick' and delete the footnote.

In item (c) delete the final paragraph and substitute the following.

'A lightweight rigid disc of appropriate material, e.g. fibre, with a minimum diameter of 99.10 mm shall be provided to separate the soil sample in the mould from the bottom face of the rammer.'

Delete paragraph 2 of item (d) and insert the following note below paragraph 1.

'NOTE. An automatic counter to indicate the number of times that the rammer has been released can be provided.'

AMD 8259/January 1995

---

### New clause 5.3.1.4

After 5.3.1.3 insert the following new clause.

'5.3.1.4 The separating disc shall be of such a size that it will pass freely through the bore of the mould. Any disc oversize shall be discarded.'

AMD 8259/January 1995

---

### Clause 7.2.2.4

In line 1, delete ' $150 \pm 5$  mm' and substitute ' $150 \pm 0.5$  mm'.

AMD 8259/January 1995

---

Figure 2. Flow chart representing sample preparation methods for compaction tests

Delete figure 2 and substitute the attached new figure 2.

NOTE. In the box headed '37.5 mm' the heading has been amended to '- 37.5 mm' and in the same box 'Exceeding 5%' has been deleted.

AMD 8259/January 1995

---



Form 4.A Dry density/moisture content relationship (rammer)

Delete the formula for bulk density and substitute the following.

$$\text{'Bulk density } \rho = \frac{m_2 - m_1}{V} ,$$

AMD 8259/January 1995

---

Form 4.B Dry density/moisture content relationship (vibration)

In rows 8 and 9, after 'base' insert 'and extension'.

In row 9 delete 'collar'.

AMD 8259/January 1995

---

Form 4.C Moisture condition

In the box headed 'Single sample/separate batches\*' delete 'Moisture content g' and substitute 'Moisture content %'.

AMD 8259/January 1995

---

Form 4.F California Bearing Ratio test

In the two central boxes reposition the row headed

'

Top	Bottom	Top	Bottom
-----	--------	-----	--------

'

above the first row of values.

AMD 8259/January 1995

---





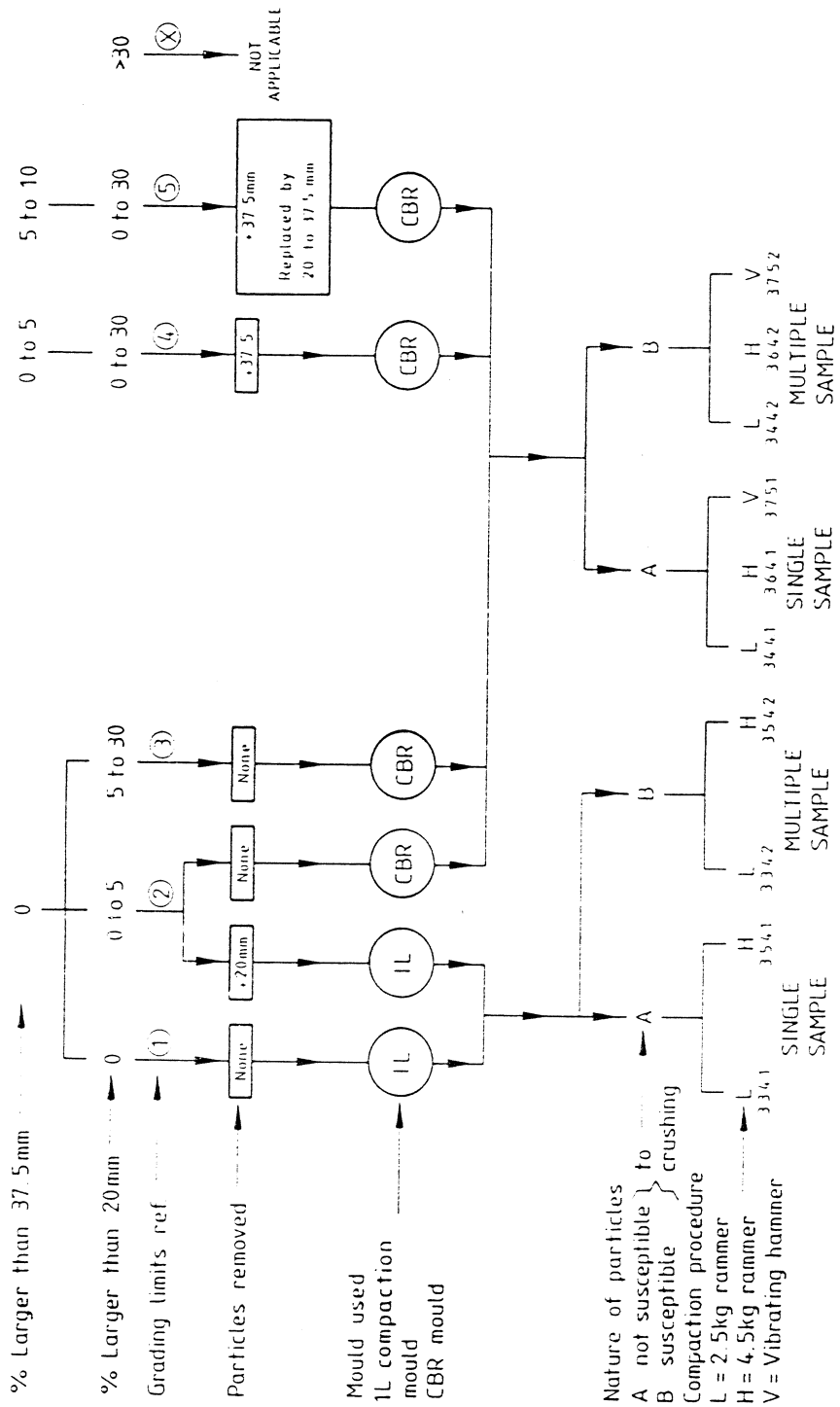



# Contents

	Page		Page
Foreword		Appendix	
Committees responsible	Inside front cover Back cover	A Typical test data and calculation forms	41
<b>Methods</b>		<b>Tables</b>	
1 Scope	2	1 Summary of compaction procedures	2
2 Definitions	2	2 Summary of sample preparation methods	3
3 Determination of dry density moisture content relationship	2	3 Standard force-penetration relationships for 100 % CBR	25
3.1 General	2	<b>Figures</b>	
3.2 Preparation of samples for compaction tests	2	1 Grading limits relating to sample preparation procedures for compaction tests	26
3.3 Method using 2.5 kg rammer for soils with particles up to medium-gravel size	5	2 Flow chart representing sample preparation methods for compaction tests	27
3.4 Method using 2.5 kg rammer for soils with some coarse gravel-size particles	7	3 Mould for compaction test (1 L mould)	28
3.5 Method using 4.5 kg rammer for soils with particles up to medium-gravel size	7	4 2.5 kg rammer for compaction test	29
3.6 Method using 4.5 kg rammer for soils with some coarse gravel-size particles	8	5 4.5 kg rammer for compaction test	30
3.7 Method using vibrating hammer	9	6 Dry density/moisture content relationship curve	31
4 Determination of maximum and minimum dry densities for granular soils	11	7 Tampers for vibrating hammer compaction test	32
4.1 General	11	8 Moisture condition apparatus	33
4.2 Determination of maximum density of sands	11	9 Relationship between change in penetration and number of blows	34
4.3 Maximum density of gravelly soils	13	10 Alternative type of relationship between change in penetration and number of blows	34
4.4 Minimum density of sands	14	11 Flow chart representing sample preparation methods for the CBR test	35
4.5 Minimum density of gravelly soils	15	12 Cylindrical mould for the determination of the California Bearing Ratio	36
4.6 Derivation of density index	15	13 Plug and collar extension for use with cylindrical mould for the determination of the California Bearing Ratio	36
5 Determination of the moisture condition value (MCV)	15	14 Apparatus for measuring the swelling of a sample during soaking for the CBR test	37
5.1 General	15	15 General arrangement of apparatus for the CBR test	38
5.2 Apparatus	16	16 Typical CBR test result curves	39
5.3 Checking the moisture condition apparatus	17	17 Force-penetration curves for a CBR value of 100 % and other CBR values	40
5.4 Determination of the MCV of a sample of soil at its natural moisture content	17		
5.5 Determination of the MCV moisture content relation of a soil	18		
5.6 Rapid assessment of whether or not a soil is stronger than a precalibrated standard	18		
6 Determination of the chalk crushing value	19		
6.1 General	19		
6.2 Apparatus	19		
6.3 Checking the moisture condition apparatus	19		
6.4 Determination of the chalk crushing value (CCV)	19		
7 Determination of the California Bearing Ratio (CBR)	20		
7.1 General	20		
7.2 Preparation of test sample	20		
7.3 Soaking	23		
7.4 Penetration test procedure	24		
7.5 Calculation and plotting	25		
7.6 Test report	26		

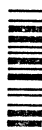

# Methods

## 1 Scope

This Part of BS 1377 describes methods of test for determining characteristics related to the compaction of soils, which can be used as a basis for specifying requirements for soils compacted in the field.

This Part also includes a method for assessing an empirical strength criterion (the CBR value) of a compacted or undisturbed soil used as a sub-grade material for pavement construction.

Reference is made to some of the classification tests described in BS 1377 : Part 2.

Reference is made to BS 1377 : Part 1 for general requirements that are relevant to all Parts of this standard, and for methods of preliminary preparation of soil for testing.

NOTE. The titles of the publications referred to in this standard are listed on the inside back cover.

## 2 Definitions

For the purposes of this Part of BS 1377, the definitions given in BS 1377 : Part 1 apply.

## 3 Determination of dry density/moisture content relationship

### 3.1 General

**3.1.1 Principle.** Compaction of soil is the process by which the solid particles are packed more closely together, usually by mechanical means, thereby increasing the dry density of the soil. The dry density which can be achieved depends on the degree of compaction applied and on the amount of water present in the soil. (The terms used in compaction tests are illustrated in figure 6.) For a given degree of compaction of a given cohesive soil there is an optimum moisture content at which the dry density obtained reaches a maximum value. For cohesionless soils an optimum moisture content might be difficult to define.

NOTE. For some highly permeable soils such as clean gravels, uniformly graded and coarse clean sands, the results of the laboratory compaction test may provide only a poor guide for specifications on field compaction. The laboratory test might indicate meaningless values of moisture content in these free-draining materials and the maximum dry density is often lower than the state of compaction which can be readily obtained in the field. For these soils one of the maximum dry density tests described in clause 4 would be more appropriate.

The objective of the tests described in this clause is to obtain relationships between compacted dry density and soil moisture content, using two magnitudes of manual compactive effort, or compaction by vibration.

**3.1.2 Types of test.** Three types of compaction test are described, each with procedural variations related to the nature of the soil. The first is the light manual compaction test in which a 2.5 kg rammer is used. The second is the heavy manual compaction test which is similar but gives a much greater degree of compaction by using a 4.5 kg rammer with a greater drop on thinner layers of soil.

For both these tests a compaction mould of 1 L internal volume is used for soil in which all particles pass a 20 mm test sieve. If there is a limited amount of particles up to 37.5 mm size, equivalent tests are carried out in the larger California Bearing Ratio (CBR) mould.

NOTE 1. Specifications for compaction by rammer in the CBR mould are based on the same compactive effort per unit volume of soil as in the 1 L compaction mould. The variable effects of side wall friction might result in differences between the densities achieved in the two moulds. For a series of tests on a particular soil, one size of mould should be used consistently.

NOTE 2. If more than 30 % of material is retained on a 20 mm test sieve the material is too coarse to be tested.

The third type of test makes use of a vibrating hammer, and is intended mainly for granular soils passing a 37.5 mm test sieve, with no more than 30 % retained on a 20 mm test sieve. The soil is compacted into a CBR mould.

For each type of test, alternative procedures depend on whether or not the soil contains particles susceptible to crushing during compaction. Methods of sample preparation covering most possible requirements are described in 3.2. Test procedures are described separately in 3.3 to 3.7.

The compaction procedures are summarized in table 1.

Test procedure clause reference	Mass of rammer	Soil particles susceptible to crushing	Type of mould used
3.3.4.1	kg 2.5	) ) no (a)	1 L
3.5.4.1	4.5	)	
3.3.4.2	2.5	) ) yes (b)	1 L
3.5.4.2	4.5	)	
3.4.4.1	2.5	) ) no (a)	CBR
3.6.4.1	4.5	)	
3.4.4.2	2.5	) ) yes (b)	CBR
3.6.4.2	4.5	)	
3.7.5.1	(vibrating hammer)	no (a)	CBR
3.7.5.2		yes (b)	
1 L = 1 L compaction mould, as described in 3.3.2.1. CBR = CBR mould, as described in 7.2.2.2. (a) and (b) refer to methods in table 2.			

### 3.2 Preparation of samples for compaction tests

**3.2.1 General.** The method of preparation of samples for these tests, and the quantity of soil required, depend on the size of the largest particles present and on whether or not the soil particles are susceptible to crushing during compaction. The assessment of these factors is covered in 3.2.2.

For soils containing particles not susceptible to crushing, one sample only is required for test and it can be used several times after progressively increasing the amount of water.

Relevant sample preparation methods are described in 3.2.4 and 3.2.5.

For soils containing particles that are susceptible to crushing, it is necessary to prepare separate batches of soil at different moisture contents, each for compacting once only, otherwise the characteristics of the material will progressively change after each application of compaction. Consequently, a much larger sample is required. Relevant sample preparation methods are described in 3.2.6 and 3.2.7.

For stiff, cohesive soils which need to be shredded or chopped into small lumps, the result of a compaction test depends on the size of the resulting pieces. Furthermore, the densities obtained in the test will not necessarily be directly related to densities obtained in situ. The method used for breaking down cohesive soil, and the size of pieces obtained, should be recorded. Suggested methods are to shred the soil so that it could pass through a 5 mm test sieve, or to chop it into pieces, e.g. to pass a 20 mm test sieve.

The requirements of Part 1 of this standard, where appropriate, shall apply to this test method.

**3.2.2 Preliminary assessment.** The initial soil sample for testing shall be obtained in accordance with the procedure described in 7.6.1 to 7.6.3 of BS 1377 : Part 1 : 1990. The procedures to be used for sample preparation and for carrying out the compaction test shall be selected on the basis of the following assessment.

- (a) Ascertain whether the soil particles are susceptible to crushing during compaction. If in doubt assume that they are susceptible.

NOTE. The soil should be considered susceptible to crushing during compaction if the sample contains granular material of a soft nature, e.g. soft limestone, sandstone, etc., which would be reduced in size by the action of the 2.5 kg rammer. The procedure described in 3.3.4.2, 3.4.4.2, 3.5.4.2, and 3.6.4.2 for soils susceptible to crushing during compaction should be applied to all soils if it is practicable to do so.

(b) Determine the approximate percentages (to an accuracy of  $\pm 5\%$ ) by mass of particles in the soil sample passing the 20 mm and 37.5 mm test sieves. If the material used for this assessment is to be used for the compaction test it shall not be dried, and the dry mass of soil finer than 20 mm may be determined by measuring the moisture content using a representative portion. If enough soil is available to meet the requirements of clause 9 of BS 1377 : Part 2 : 1990 a separate sample may be used for this sieving operation.

(c) On the basis of these percentages the soil can be assigned to one of the grading zones (1) to (5) in table 2, which are also shown diagrammatically in figure 1. If a grading curve passes through more than one zone the highest-numbered zone applies. A soil with a grading curve passing through zone X is not suitable for these tests.

(d) The method of sample preparation, the minimum mass of soil required, and the type of mould to use for the compaction test are indicated in table 2, which takes account of the above factors.

(e) The selection of methods is also shown in the form of a flow chart in figure 2.

### 3.2.3 Apparatus

**3.2.3.1 Test sieves**, with aperture sizes 63 mm, 37.5 mm, 20 mm, with receiver.

**3.2.3.2 A balance** readable to 5 g.

**3.2.3.3 A balance** readable to 1 g.

**3.2.3.4 A corrosion-resistant metal or plastics tray with sides**, e.g. about 80 mm deep, of a size suitable for the quantity of material to be used.

Table 2. Summary of sample preparation methods

Grading zone	Minimum percentage passing test sieves		Preparation procedure clause reference		Minimum mass of prepared soil required		Type of mould used	
	20 mm	37.5 mm	(a)	(b)	(a)	(b)		
(1)	100%	100%	3.2.4.1	3.2.6.1	) kg	kg	1 L	
(2)	95	100	3.2.4.2	3.2.6.2	) 6	15		
(3)	70	100	3.2.5.1	3.2.7.1	)		CBR	
(4)	70	95	3.2.5.2	3.2.7.2	) 15	40		
(5)	70	90	3.2.5.3	3.2.7.3	)			
(X)	less than 70	less than 90	(Tests not applicable)					

(a) Soil particles not susceptible to crushing during compaction.

(b) Soil particles susceptible to crushing during compaction.

1 L = one-litre compaction mould.

CBR = CBR mould.

**3.2.3.5** *A large metal scoop.*

**3.2.3.6** *A palette knife or spatula.*

**3.2.3.7** *Watertight containers, e.g. strong polythene bags.*

**3.2.3.8** *Apparatus for determination of moisture content as described in 3.2 of BS 1377 : Part 2 : 1990.*

**3.2.3.9** *An implement for shredding stiff, cohesive soil.*

**3.2.4** *Preparation of soils not susceptible to crushing for compaction in 1 L mould.*

**3.2.4.1** *Grading zone (1) for soils passing the 20 mm test sieve.*

**3.2.4.1.1** Prepare and subdivide the initial sample by the procedures described in 7.6 of BS 1377 : Part 1 : 1990 to produce a representative sample of about 6 kg of the soil.

**3.2.4.1.2** Add a suitable amount of water depending on the soil type and mix thoroughly.

**NOTE 1.** The amount of water to be mixed with soil at the commencement of the test will vary with the type of soil under test. In general, with sandy and gravelly soils a moisture content of 4 % to 6 % would be suitable, while with cohesive soils a moisture content about 8 % to 10 % below the plastic limit of the soil would usually be suitable.

**NOTE 2.** It is important that the water is mixed thoroughly and adequately with the soil, since inadequate mixing gives rise to variable test results. This is particularly important with cohesive soils when adding a substantial quantity of water. With clays of high plasticity, or where hand mixing is used, storage of the mixed sample in a sealed container for a minimum period of 24 h before continuing with the test is the most satisfactory way of distributing the water uniformly.

**3.2.4.1.3** If the soil initially contains too much water allow it to partially air dry to the lowest moisture content at which the soil is to be compacted, and mix thoroughly.

**3.2.4.1.4** If the soil is cohesive, seal in an airtight container and store for at least 24 h.

**3.2.4.2.** *Grading zone (2) for soils passing the 37.5 mm test sieve with at least 95 % passing the 20 mm test sieve*

**3.2.4.2.1** Weigh to 0.1 % by mass the whole sample and record the mass.

**3.2.4.2.2** Remove and weigh to 0.1 % by mass the material retained on the 20 mm test sieve.

**NOTE.** The removal of small amounts of stone (up to 5 %) retained on a 20 mm test sieve is likely to affect the density obtainable only by amounts comparable with the experimental error involved in measuring the maximum dry density.

**3.2.4.2.3** Subdivide the finer material and proceed as described in 3.2.4.1.

Alternatively, the whole sample can be used as described in 3.2.5.1 for compaction in a CBR mould.

**3.2.5** *Preparation of soils not susceptible to crushing for compaction in CBR mould*

**3.2.5.1** *Grading zone (3) for soils passing the 37.5 mm test sieve with 70 % to 95 % passing the 20 mm test sieve*

Prepare and subdivide the initial sample using the procedure described in 7.6 of BS 1377 : Part 1 : 1990 to produce a representative sample of about 15 kg of the soil, otherwise proceed as described in 3.2.4.1.

**3.2.5.2** *Grading zone (4) for soils containing at least 95 % passing the 37.5 mm test sieve and at least 70 % passing the 20 mm test sieve*

**3.2.5.2.1** Weigh the whole sample and record the mass.

**3.2.5.2.2** Remove and weigh the material retained on the 37.5 mm test sieve.

**NOTE.** The exclusion of the large proportion of particles coarser than 20 mm from this type of soil could have a large effect on the density obtained in the compaction mould compared with that obtainable with the soil as a whole, and the optimum moisture content would also be affected. The larger CBR mould is therefore specified for this type of material.

**3.2.5.2.3** Subdivide the finer material to produce a 25 kg sample, otherwise proceed as described in 3.2.4.1.

**3.2.5.3** *Grading zone (5) for soils with 90 % to 95 % passing the 37.5 mm test sieve, and at least 70 % passing the 20 mm test sieve*

**3.2.5.3.1** Weigh the soil sample.

**3.2.5.3.2** Remove and weigh the material retained on the 37.5 mm test sieve.

**3.2.5.3.3** Replace this material by the same quantity of material of similar characteristics which passes the 37.5 mm test sieve and is retained on the 20 mm test sieve.

**NOTE.** The substitution of large particles by smaller, similar particles is generally considered to give dry densities in the laboratory test which compare reasonably well with those obtained in the field. Alternatively the coarser material can be removed for the test and a correction applied to the maximum dry density based on the displacement of the soil matrix by stones of known particle density.

**3.2.5.3.4** Subdivide the material to produce a sample of approximately 15 kg of the soil, otherwise proceed as described in 3.2.4.1.

**3.2.6** *Preparation of soils susceptible to crushing for compaction in 1 L mould*

**3.2.6.1** *Grading zone (1) for soils passing the 20 mm test sieve*

**3.2.6.1.1** Subdivide the initial sample to produce five or more representative samples, each of about 2.5 kg, using the procedure described in 7.6 of BS 1377 : Part 1 : 1990.

**3.2.6.1.2** Mix each sample thoroughly with a different amount of water to give a suitable range of moisture contents (see notes 1 and 2 to 3.2.4.1.2). The range of moisture contents shall be such that at least two values lie either side of the optimum at which the maximum dry density occurs.

**NOTE.** The water added to each sample should be such that a range of moisture contents is obtained which includes the optimum moisture content. In general, increments of 1 % to 2 % are suitable for sandy and gravelly soils and of 2 % to 4 % for cohesive soils. To increase the accuracy of the test it might be desirable to prepare samples with smaller increments of water in the region of the optimum moisture content.

**3.2.6.1.3** If the soil initially contains more water than is required for the compaction at the lower moisture contents, allow these samples to partially dry to the desired moisture contents, and mix thoroughly.

**3.2.6.1.4** If the soil is cohesive seal each sample in an airtight container and store for at least 24 h.

**3.2.6.2** *Grading zone (2) for soils passing the 37.5 mm test sieve with at least 95 % passing the 20 mm test sieve*

**3.2.6.2.1** Weigh the whole sample and record the mass.

**3.2.6.2.2** Remove and discard the material retained on the 20 mm test sieve (see note to **3.2.4.2.2**).

**3.2.6.2.3** Subdivide the finer material, and proceed as described in **3.2.6.1**.

Alternatively, the whole sample can be used as described in **3.2.7.1** for compaction in a CBR mould.

**3.2.7** *Preparation of soils susceptible to crushing for compaction in CBR mould*

**3.2.7.1** *Grading zone (3) for soil passing the 37.5 mm test sieve with 70 % to 95 % passing the 20 mm test sieve*

Subdivide the initial sample to produce five or more representative samples each of approximately 6 kg using the procedure described in 7.6 of BS 1377 : Part 1 : 1990, otherwise proceed as described in **3.2.6.1**.

**3.2.7.2** *Grading zone (4) for soils containing at least 95 % passing the 37.5 mm test sieve and at least 70 % passing the 20 mm test sieve*

**3.2.7.2.1** Weigh the whole sample and record the mass.

**3.2.7.2.2** Remove and weigh the material retained on the 37.5 mm test sieve (see note to **3.2.5.2.2**).

**3.2.7.2.3** Subdivide the finer material, and proceed as described in **3.2.7.1**.

**3.2.7.3** *Grading zone (5) for soils containing 90 % to 95 % passing the 37.5 mm test sieve, and at least 70 % passing the 20 mm test sieve*

**3.2.7.3.1** Weigh the soil sample.

**3.2.7.3.2** Remove and weigh the material retained on the 37.5 mm test sieve.

**3.2.7.3.3** Replace this material by the same quantity of material of similar characteristics which passes the 37.5 mm test sieve and is retained on the 20 mm test sieve. (See note to **3.2.5.3.3**).

**3.2.7.3.4** Subdivide the material to produce five or more 6 kg samples of the soil, otherwise proceed as described in **3.2.6.1**.

### **3.3** Method using 2.5 kg rammer for soils with particles up to medium-gravel size

**3.3.1** *General.* This test covers the determination of the dry density of soil passing a 20 mm test sieve when it is compacted in a specified manner over a range of moisture contents. The range includes the optimum moisture content

at which the maximum dry density for this degree of compaction is obtained. In this test a 2.5 kg rammer falling through a height of 300 mm is used to compact the soil in three layers into a 1 L compaction mould.

The requirements of Part 1 of this standard, where appropriate, shall apply to this test method.

#### **3.3.2** Apparatus

**3.3.2.1** *A cylindrical, corrosion-resistant metal mould*, i.e. the compaction mould, having a nominal internal volume of 1 L. The mould shall be fitted with a detachable baseplate and a removable extension. The essential dimensions are shown in figure 3 which also indicates one suitable design of mould. The internal faces shall be smooth, clean and dry before each use.

**3.3.2.2** *A metal rammer* having a  $50 \pm 0.5$  mm diameter circular face, and weighing  $2.5 \text{ kg} \pm 25 \text{ g}$ . The rammer shall be equipped with a suitable arrangement for controlling the height of drop to  $300 \pm 3$  mm. One suitable form of hand apparatus is shown in figure 4.

NOTE. A motorized form of the apparatus may be used provided that the essential dimensions of the rammer and mould are adhered to, and provided that the density achieved is within  $\pm 2$  % of the density achieved by using the hand rammer. The machine should be firmly supported on a heavy solid base such as a concrete floor or plinth.

**3.3.2.3** *A balance* readable to 1 g.

**3.3.2.4** *A palette knife or spatula.*

**3.3.2.5** *A straightedge*, e.g. a steel strip about 300 mm long, 25 mm wide, and 3 mm thick, with one bevelled edge.

**3.3.2.6** *Test sieves*, of aperture sizes 37.5 mm and 20 mm and a receiver.

**3.3.2.7** *A corrosion-resistant metal or plastics tray with sides*, e.g. about 80 mm deep, of a size suitable for the quantity of material to be used.

**3.3.2.8** *Apparatus for moisture content determination*, as described in **3.2** of BS 1377 : Part 2 : 1990.

**3.3.2.9** *Apparatus for extracting specimens from the mould* (optional).

**3.3.3** *Preparation of sample.* Prepare the test sample as described in **3.2.4.1**, **3.2.4.2**, **3.2.6.1** or **3.2.6.2** as appropriate.

#### **3.3.4** Procedure

**3.3.4.1** *Compaction procedure for soil particles not susceptible to crushing*

**3.3.4.1.1** Weigh the mould with baseplate attached to 1 g ( $m_1$ ).

Measure the internal dimensions to 0.1 mm.

**3.3.4.1.2** Attach the extension to the mould and place the mould assembly on a solid base, e.g. a concrete floor or plinth.

**3.3.4.1.3** Place a quantity of moist soil in the mould such that when compacted it occupies a little over one-third of the height of the mould body.

**3.3.4.1.4** Apply 27 blows from the rammer dropped from a height of 300 mm above the soil as controlled by the guide tube. Distribute the blows uniformly over the surface and ensure that the rammer always falls freely and is not obstructed by soil in the guide tube.

**3.3.4.1.5** Repeat 3.3.4.1.3 and 3.3.4.1.4 twice more, so that the amount of soil used is sufficient to fill the mould body, with the surface not more than 6 mm proud of the upper edge of the mould body.

NOTE. It is necessary to control the total volume of soil compacted, since it has been found that if the amount of soil struck off after removing the extension is too great, the test results will be inaccurate.

**3.3.4.1.6** Remove the extension, strike off the excess soil and level off the surface of the compacted soil carefully to the top of the mould using the straightedge. Replace any coarse particles, removed in the levelling process, by finer material from the sample, well pressed in.

**3.3.4.1.7** Weigh the soil and mould with baseplate to 1 g ( $m_2$ ).

**3.3.4.1.8** Remove the compacted soil from the mould and place it on the metal tray. Take a representative sample of the soil for determination of its moisture content as described in 3.2 of BS 1377 : Part 2 : 1990.

**3.3.4.1.9** Break up the remainder of the soil, rub it through the 20 mm test sieve and mix with the remainder of the prepared test sample.

**3.3.4.1.10** Add a suitable increment of water and mix thoroughly into the soil.

NOTE. The water added for each stage of the test should be such that a range of moisture contents is obtained which includes the optimum moisture content. In general, increments of 1 % to 2 % are suitable for sandy and gravelly soils and of 2 % to 4 % for cohesive soils. To increase the accuracy of the test it is often advisable to reduce the increments of water in the region of the optimum moisture content.

**3.3.4.1.11** Repeat 3.3.4.1.3 to 3.3.4.1.10 to give a total of at least five determinations. The moisture contents shall be such that the optimum moisture content, at which the maximum dry density occurs, lies near the middle of the range.

**3.3.4.2** *Compaction procedure for soil particles susceptible to crushing*

**3.3.4.2.1** Weigh, measure and prepare the mould as described in 3.3.4.1.1 and 3.3.4.1.2.

**3.3.4.2.2** Carry out a compaction test on each of the prepared samples as described in 3.3.4.1.3 to 3.3.4.1.8.

**3.3.4.2.3** Discard the remainder of each compacted sample.

**3.3.5** *Calculations, plotting and expression of results* (see form 4.A of appendix A)

**3.3.5.1** Calculate the internal volume,  $V$  (in  $\text{cm}^3$ ), of the mould.

**3.3.5.2** Calculate the bulk density,  $\rho$  (in  $\text{Mg/m}^3$ ), of each compacted specimen from the equation

$$\rho = \frac{m_2 - m_1}{V}$$

where

$m_1$  is the mass of mould and baseplate (in g);

$m_2$  is the mass of mould, baseplate and compacted soil (in g).

**3.3.5.3** Calculate the dry density,  $\rho_s$  (in  $\text{Mg/m}^3$ ), of each compacted specimen from the equation

$$\rho_s = \frac{100 \rho}{100 + w}$$

where

$w$  is the moisture content of the soil (in %).

**3.3.5.4** Plot the dry densities obtained from a series of determinations as ordinates against the corresponding moisture contents as abscissae. Draw a curve of best fit to the plotted points and identify the position of the maximum on this curve. Read off the values of dry density and moisture content, to three significant figures, corresponding to that point. (See figure 6.)

NOTE. The maximum may lie between two observed points but when drawing the curve, care should be taken not to exaggerate its peak.

**3.3.5.5** On the same graph, plot the curves corresponding to 0 %, 5 % and 10 % air voids, calculated from the equation

$$\rho_s = \frac{1 - \frac{V_a}{100}}{\frac{1}{\rho_s} + \frac{w}{100 \rho_w}}$$

where

$\rho_s$  is the dry density (in  $\text{Mg/m}^3$ );

$\rho_s$  is the particle density (in  $\text{Mg/m}^3$ );

$\rho_w$  is the density of water (in  $\text{Mg/m}^3$ ), assumed equal to 1;

$V_a$  is the volume of air voids in the soil, expressed as a percentage of the total volume of the soil (equal to 0 %, 5 %, 10 % for the purpose of this plot);

$w$  is the moisture content (in %).

(See figure 6.)

**3.3.6** *Test report.* The test report shall affirm that the test was carried out in accordance with this Part of this standard and shall contain the following information:

- the method of test used;
- the sample preparation procedure, and whether a single sample or separate samples were used. In the case of stiff, cohesive soil the size of pieces to which the soil was broken down shall be stated;
- the experimental points and the smooth curve drawn through them showing the relationship between moisture content and dry density;
- the dry density corresponding to the maximum dry density on the moisture content/dry density curve, reported as the maximum dry density to the nearest 0.01 (in  $\text{Mg/m}^3$ );
- the percentage moisture content corresponding to the maximum dry density on the moisture content/dry density curve reported as the optimum moisture content to two significant figures;



- (f) the amount of stone retained on the 20 mm and 37.5 mm test sieves reported to the nearest 1 % by dry mass;
- (g) the particle density and whether measured (and if so the method used) or assumed;
- (h) the information required by 9.1 of BS 1377 : Part 1 : 1990.

### 3.4 Method using 2.5 kg rammer for soils with some coarse gravel-size particles

**3.4.1 General.** This test covers the determination of the dry density of soil containing some coarse gravel when it is compacted in a specified manner over a range of moisture contents. The range includes the optimum moisture content at which the maximum dry density for this degree of compaction is obtained. In this test a 2.5 kg rammer falling through a height of 300 mm is used to compact the soil in three layers into a CBR mould.

The test is suitable for soils containing no more than 30 % by mass of material retained on the 20 mm test sieve, which may include some particles retained on the 37.5 mm test sieve.

NOTE. This method may also be used for finer soils which would normally be compacted in the 1 L mould when it is required to perform a CBR test (see 7.4) on the compacted soil at each moisture content.

The requirements of Part 1 of this standard, where appropriate, shall apply to this test method.

#### 3.4.2 Apparatus

**3.4.2.1** A cylindrical, corrosion-resistant, metal mould, i.e. the CBR mould, with a detachable baseplate and a removable extension as described in 7.2.2.2.

**3.4.2.2** A hand or motorized, metal rammer, having a 50 mm diameter circular face, and weighing 2.5 kg, as described in 3.3.2.2.

**3.4.2.3** A balance readable to 5 g.

**3.4.2.4** A large scoop.

**3.4.2.5** Other items as specified in 3.3.2.4 to 3.3.2.9.

**3.4.3 Preparation of sample.** Prepare the test sample as described in 3.2.5.1, 3.2.5.2, 3.2.5.3, 3.2.7.1, 3.2.7.2 or 3.2.7.3 as appropriate.

#### 3.4.4 Procedure

**3.4.4.1** *Compaction procedure for soil particles not susceptible to crushing*

**3.4.4.1.1** Weigh the CBR mould with baseplate attached, to 5 g ( $m_1$ ).

Measure the internal dimensions to 0.5 mm.

**3.4.4.1.2** Attach the extension to the mould and place the mould assembly on a solid base, e.g. a concrete floor or plinth.

**3.4.4.1.3** Place a quantity of moist soil in the mould such that when compacted it occupies a little over one-third of the height of the mould body.

**3.4.4.1.4** Apply 62 blows from the rammer dropped from a height of 300 mm above the soil. Distribute the blows uniformly over the surface and ensure that the rammer always falls freely and is not obstructed by soil in the guide tube.

**3.4.4.1.5** Repeat 3.4.4.1.3 and 3.4.4.1.4 twice more, so that the amount of soil is sufficient to fill the mould body, with the surface not more than 6 mm proud of the upper edge of the mould body.

NOTE. It is necessary to control the total volume of soil compacted, since it has been found that if the amount of soil struck off after removing the extension is too great, the test results will be inaccurate.

**3.4.4.1.6** Remove the extension, strike off the excess soil and level off the surface of the compacted soil carefully to the top of the mould using the straightedge. Any coarse particles removed in the levelling process shall be replaced by finer material from the sample, well pressed in.

**3.4.4.1.7** Weigh the soil and mould with baseplate to 5 g ( $m_2$ ).

**3.4.4.1.8** Remove the compacted soil from the mould and place it on the metal tray. Take a representative sample of the soil for determination of its moisture content as described in 3.2 of BS 1377 : Part 2 : 1990.

**3.4.4.1.9** Break up the remainder of the soil, rub it through the 20 mm or the 37.5 mm test sieve and mix with the remainder of the prepared test sample.

**3.4.4.1.10** Add a suitable increment of water and mix thoroughly into the soil.

NOTE. The water added for each stage of the test should be such that a range of moisture contents is obtained which includes the optimum moisture content. In general, increments of 1 % to 2 % are suitable for sandy and gravelly soils and of 2 % to 4 % for cohesive soils. To increase the accuracy of the test it is often advisable to reduce the increments of water in the region of the optimum moisture content.

**3.4.4.1.11** Repeat 3.4.4.1.3 to 3.4.4.1.10 to give a total of at least five determinations. The moisture contents shall be such that the optimum moisture content, at which the maximum dry density occurs, lies near the middle of the range.

**3.4.4.2** *Compaction procedure for soil particles susceptible to crushing*

**3.4.4.2.1** Weigh, measure and prepare the CBR mould as described in 3.4.4.1.1 and 3.4.4.1.2.

**3.4.4.2.2** Carry out a compaction test on each of the prepared samples in turn as described in 3.4.4.1.3. to 3.4.4.1.8.

**3.4.4.2.3** Discard the remainder of each compacted sample.

**3.4.5** *Calculations, plotting and expression of results.* Proceed as described in 3.3.5.

**3.4.6** *Test report.* The test report shall comply with 3.3.6.

### 3.5 Method using 4.5 kg rammer for soils with particles up to medium-gravel size

**3.5.1 General.** This test covers the determination of the dry density of soil passing a 20 mm test sieve when it is compacted in a specified manner over a range of moisture contents. The range includes the optimum moisture content

at which the maximum dry density for this degree of compaction is obtained. In this test the compactive effort is greater than in that described in 3.3, the mass of the rammer being increased to 4.5 kg, the height of fall to 450 mm, and the number of compacted layers from three to five. The same 1 L compaction mould is used.

The requirements of Part 1 of this standard, where appropriate, shall apply to this test method.

### 3.5.2 Apparatus

3.5.2.1 A cylindrical corrosion-resistant metal mould, i.e. the 1 L compaction mould, as specified in 3.3.2.1.

3.5.2.2 A metal rammer, having a  $50 \pm 0.5$  mm diameter circular face, and weighing  $4.5 \text{ kg} \pm 50 \text{ g}$ . The rammer shall be equipped with a suitable arrangement for controlling the height of drop to  $450 \pm 4$  mm. One suitable form of hand apparatus is shown in figure 5.

NOTE. A motorized form of the apparatus may be used provided that the essential dimensions of the rammer and mould are adhered to, and provided that the density achieved is within  $\pm 2\%$  of the density achieved by using the hand rammer. The machine should be supported on a heavy solid base such as a concrete floor or plinth.

3.5.2.3 Other items, as specified in 3.3.2.3 to 3.3.2.9.

3.5.3 Preparation of soil. Prepare the test sample as described in 3.2.4.1, 3.2.4.2, 3.2.6.1 or 3.2.6.2 as appropriate.

### 3.5.4 Procedure

3.5.4.1 Compaction procedure for soil particles not susceptible to crushing

3.5.4.1.1 Weigh the mould with baseplate attached to 1 g ( $m_1$ ).

Measure the internal dimensions to 0.1 mm.

3.5.4.1.2 Attach the extension to the mould and place the mould assembly on a solid base, e.g. a concrete floor or plinth.

3.5.4.1.3 Place a quantity of moist soil in the mould such that when compacted it occupies a little over one-fifth of the height of the mould body.

3.5.4.1.4 Apply 27 blows from the rammer dropped from a height of 450 mm above the soil as controlled by the guide tube. Distribute the blows uniformly over the surface and ensure that the rammer always falls freely and is not obstructed by soil in the guide tube.

3.5.4.1.5 Repeat 3.5.4.1.3 and 3.5.4.1.4 four more times, so that the amount of soil used is sufficient to fill the mould body, with the surface not more than 6 mm proud of the upper edge of the mould body. (See note to 3.3.4.1.5)

3.5.4.1.6 Remove the extension, strike off the excess soil and level off the surface of the compacted soil carefully to the top of the mould using the straightedge. Replace any coarse particles removed in the levelling process, by finer material from the sample, well pressed in.

3.5.4.1.7 Weigh the soil and mould with baseplate to 1 g ( $m_2$ ).

3.5.4.1.8 Remove the compacted soil from the mould and place it on the large metal tray. Take a representative sample of the soil for determination of its moisture content as described in 3.2 of BS 1377 : Part 2 : 1990.

3.5.4.1.9 Break up the remainder of the soil, rub it through the 20 mm test sieve and mix with the remainder of the prepared test sample.

3.5.4.1.10 Add a suitable increment of water (see note to 3.3.4.1.10) and mix it thoroughly into the soil.

3.5.4.1.11 Repeat 3.5.4.1.3 to 3.5.4.1.10 to give a total of at least five determinations. The moisture contents shall be such that the optimum moisture content, at which the maximum dry density occurs, lies near the middle of the range.

3.5.4.2 Compaction procedure for soil particles susceptible to crushing

3.5.4.2.1 Weigh, measure and prepare the mould as described in 3.5.4.1.1 and 3.5.4.1.2.

3.5.4.2.2 Carry out a compaction test on each of the prepared samples in turn as described in 3.5.4.1.3 to 3.5.4.1.8.

3.5.4.2.3 Discard the remainder of each compacted sample.

3.5.5 Calculations, plotting and expression of results. Proceed as described in 3.3.5.

3.5.6 Test report. The test report shall comply with 3.3.6.

## 3.6 Method using 4.5 kg rammer for soils with some coarse gravel-size particles

3.6.1 General. This test covers the determination of the dry density of soil containing some coarse gravel when it is compacted in a specified manner over a range of moisture contents. The range includes the optimum moisture content at which the maximum dry density for this degree of compaction is obtained. In this test the compactive effort is greater than in that described in 3.4, the mass of the rammer being increased to 4.5 kg, the height of fall to 450 mm, and the number of compacted layers from three to five. The soil is compacted into a CBR mould.

The test is suitable for soils containing no more than 30 % by mass of material retained on the 20 mm test sieve, which may include some particles retained on the 37.5 mm test sieve. (See note to 3.4.1.)

The requirements of Part 1 of this standard, where appropriate, shall apply to this test method.

### 3.6.2 Apparatus

3.6.2.1 A cylindrical, corrosion-resistant metal mould, i.e. the CBR mould, as described in 7.2.2.2.

3.6.2.2 A hand or motorized metal rammer weighing 4.5 kg, as described in 3.5.2.2.

3.6.2.3 A balance readable to 5 g.

3.6.2.4 A large scoop

3.6.2.5 Other items as specified in 3.3.2.4 to 3.3.2.9.

**3.6.3 Preparation of sample.** Prepare the test sample as described in 3.2.5.1, 3.2.5.2, 3.2.5.3, 3.2.7.1, 3.2.7.2 or 3.2.7.3 as appropriate.

### 3.6.4 Procedure

**3.6.4.1 Compaction procedure for soil particles not susceptible to crushing**

**3.6.4.1.1** Weigh the mould with baseplate attached to 5 g ( $m_1$ ).

Measure the internal dimensions to 0.5 mm.

**3.6.4.1.2** Attach the extension to the mould and place the mould assembly on a solid base, e.g. a concrete floor or plinth.

**3.6.4.1.3** Place a quantity of moist soil in the mould such that when compacted it occupies a little over one-fifth of the height of the mould body.

**3.6.4.1.4** Apply 62 blows from the rammer dropped from a height of 450 mm above the soil as controlled by the guide tube. Distribute the blows uniformly over the surface and ensure that the rammer always falls freely and is not obstructed by soil in the guide tube.

**3.6.4.1.5** Repeat 3.6.4.1.3 and 3.6.4.1.4 four more times, so that the amount of soil used is sufficient to fill the mould body, with the surface not more than 6 mm proud of the upper edge of the mould body. (See note to 3.4.4.1.5.)

**3.6.4.1.6** Remove the extension, strike off the excess soil and level off the surface of the compacted soil carefully to the top of the mould using the straightedge. Replace any coarse particles, removed in the levelling process, by finer material from the sample, well pressed in.

**3.6.4.1.7** Weigh the soil and mould with baseplate to 5 g ( $m_2$ ).

**3.6.4.1.8** Remove the compacted soil from the mould and place it on the large metal tray. Take a representative sample of the soil for determination of its moisture content as described in 3.2 of BS 1377 : Part 2 : 1990.

**3.6.4.1.9** Break up the remainder of the soil, rub it through the 20 mm or the 37.5 mm test sieve and mix with the remainder of the prepared test sample.

**3.6.4.1.10** Add a suitable increment of water (see note to 3.4.4.1.10) and mix thoroughly into the soil.

**3.6.4.1.11** Repeat 3.6.4.1.3. to 3.6.4.1.10 to give a total of at least five determinations. The moisture contents shall be such that the optimum moisture content, at which the maximum dry density occurs, lies near the middle of the range.

**3.6.4.2 Compaction procedure for soil particles susceptible to crushing**

**3.6.4.2.1** Weigh, measure and prepare the mould as described in 3.6.4.1.1 and 3.6.4.1.2.

**3.6.4.2.2** Carry out a compaction test on each of the prepared samples as described in 3.6.4.1.3 to 3.6.4.1.8.

**3.6.4.2.3** Discard the remainder of each compacted sample.

**3.6.5 Calculations, plotting and expression of results.** Proceed as described in 3.3.5.

**3.6.6 Test report.** The test report shall comply with 3.3.6.

### 3.7 Method using vibrating hammer

**3.7.1 General.** This test covers the determination of the dry density of soil, which may contain some particles up to coarse gravel size, when it is compacted by vibration in a specified manner over a range of moisture contents. The range includes the optimum moisture content at which the maximum dry density for the specified degree of compaction is obtained. In this test the soil is compacted into a CBR mould using an electrically operated vibrating hammer.

The test is suitable for certain soils containing no more than 30 % by mass of material retained on the 20 mm test sieve, which may include some particles retained on the 37.5 mm test sieve. It is not generally suitable for cohesive soils.

The requirements of Part 1 of this standard, where appropriate, shall apply to this test method.

#### 3.7.2 Apparatus

**3.7.2.1** A cylindrical, corrosion-resistant metal mould, i.e. the CBR mould, as described in 7.2.2.2.

**3.7.2.2** An electric vibrating hammer having a power consumption between 600 W and 750 W and operating at a frequency between 25 Hz to 45 Hz.

NOTE. For safety reasons the vibrating hammer should operate on 110 V, and an earth leakage circuit breaker should be included between the hammer and the mains supply.

**3.7.2.3** A steel tamper for attachment to the vibrating hammer. Essential dimensions are shown in figure 7(b), which also indicates one suitable design of tamper.

**3.7.2.4** Supporting guide frame for vibrating hammer (optional).

**3.7.2.5** A depth gauge or steel rule, or other device which enables the sample depth to be measured to an accuracy of 0.5 mm.

**3.7.2.6** A balance readable to 5 g.

**3.7.2.7** A straightedge, e.g. a steel strip about 300 mm long, 25 mm wide, and 3 mm thick, with one bevelled edge.

**3.7.2.8** Test sieves, of aperture sizes 37.5 mm and 20 mm, and receiver.

**3.7.2.9** A corrosion-resistant metal or plastics tray with sides, e.g. about 80 mm deep, of a size suitable for the quantity of material to be used.

**3.7.2.10** A scoop.

**3.7.2.11** Apparatus for the determination of moisture content as described in 3.2 of BS 1377 : Part 2 : 1990.

**3.7.2.12** A stopclock readable to 1 s.

**3.7.2.13** Apparatus for extracting compacted specimens from the mould (optional).

### 3.7.3 Calibration of vibrating hammer

**3.7.3.1 General.** The vibrating hammer shall be maintained in accordance with the manufacturer's instructions. Its working parts shall not be badly worn.

The calibration test described in 3.7.3.3 shall be carried out to determine whether the vibrating hammer is in satisfactory working order, and able to comply with the requirements of the test described in 3.7.5.

The pressure check described in 3.7.3.4 shall be made by the operator carrying out the calibration test.

**3.7.3.2 Material.** Clean, dry, silica sand, from the Woburn Beds of the Lower Greensand in the Leighton Buzzard district\*. The grading shall be such that 100 % passes a 600  $\mu\text{m}$  test sieve and 100 % is retained on a 63  $\mu\text{m}$  test sieve. The sand shall be free from flaky particles, silt, clay and organic matter.

#### 3.7.3.3 Calibration test

**3.7.3.3.1** Take a 5  $\pm$  0.1 kg sample of the sand specified in 3.7.3.2, which has not been used previously, and mix it with water in order to raise its moisture content to 2.5  $\pm$  0.5 %.

**3.7.3.3.2** Compact the wet sand in a cylindrical metal mould of 152 mm diameter and 127 mm depth, using the vibrating hammer as specified in 3.7.5.1.

NOTE. The operator can usually judge the required pressure to apply with sufficient accuracy after first carrying out the check described in 3.7.3.4.

**3.7.3.3.3** Carry out a total of three tests, all on the same sample of sand, and determine the mean dry density. Determine the dry density values to the nearest 0.002  $\text{Mg}/\text{m}^3$ .

**3.7.3.3.4** If the range of values in the three tests exceeds 0.01  $\text{Mg}/\text{m}^3$ , repeat the procedure. Consider the vibrating hammer suitable for use in the vibrating compaction test if the mean dry density of the sand exceeds 1.74  $\text{Mg}/\text{m}^3$ .

**3.7.3.4 Pressure check.** Apply pressure combined with vibration to ensure the required degree of compaction. A downward force on the sample surface of 300 N to 400 N shall be applied, this being greater than the force needed to prevent the hammer bouncing on the soil.

The required pressure shall be assessed by applying the vibrating hammer, without vibration, to a platform scale. The required force is applied when a mass of 30 kg to 40 kg is indicated.

**3.7.4 Preparation of sample.** Prepare the test sample as described in 3.2.5.1, 3.2.5.2, 3.2.5.3, 3.2.7.1, 3.2.7.2 or 3.2.7.3 as appropriate.

### 3.7.5 Procedure

**3.7.5.1 Compaction procedure for soil particles not susceptible to crushing**

**3.7.5.1.1** Weigh the mould, with baseplate attached, to 5 g ( $m_1$ ).

Measure the internal dimensions to 0.5 mm.

**3.7.5.1.2** Attach the extension to the mould and place the mould assembly on a solid base, e.g. a concrete floor or plinth.

**3.7.5.1.3** Place a quantity of moist soil in the mould such that when compacted it occupies a little over one-third of the height of the mould body.

**3.7.5.1.4** Place the circular tamper on the soil and compact with the vibrating hammer for 60  $\pm$  2 s. During this period apply a steady downward force on the hammer so that the total downward force on the sample, including that from the mass of the hammer, is between 300 N and 400 N. (See note to 3.7.3.3.2).

NOTE. A disc of polyethylene sheet may be placed immediately beneath the tamper plate to prevent sand particles moving up through the annular gap.

**3.7.5.1.5** Repeat 3.7.5.1.3 and 3.7.5.1.4 twice more.

**3.7.5.1.6** Remove any loose material lying on the surface of the sample around the sides of the mould.

**3.7.5.1.7** Lay a straightedge across the top of the extension collar and measure down to the surface of the sample to an accuracy of 0.5 mm. Take readings at four points spaced evenly over the surface of the sample, all at least 15 mm from the side of the mould. Calculate the mean height,  $h$  (in mm), of the sample. If the sample is less than 127 mm or more than 133 mm in height, reject it and repeat the test from 3.7.5.1.3 until a sample of the required height is obtained.

**3.7.5.1.8** Weigh the soil and mould with baseplate to 5 g (in  $m_2$ ).

**3.7.5.1.9** Remove the compacted soil from the mould and place it on the metal tray. Take a representative sample of the soil for determination of its moisture content as described in 3.2 of BS 1377 : Part 2 : 1990.

**3.7.5.1.10** Break up the remainder of the soil, rub it through the 20 mm or the 37.5 mm test sieve and mix with the remainder of the prepared test sample.

**3.7.5.1.11** Add a suitable increment of water and mix thoroughly into the soil.

NOTE. The water added for each stage of the test should be such that a range of moisture contents is obtained which includes the optimum moisture content. In general, increments of 1 % to 2 % are suitable for sandy and gravelly soils. To increase the accuracy of the test it is often advisable to reduce the increments of water in the region of the optimum moisture content.

**3.7.5.1.12** Repeat 3.7.5.1.3 to 3.7.5.1.11 to give a total of at least five determinations. The moisture contents shall be such that the optimum moisture content, at which the maximum dry density occurs, lies near the middle of the range.

**3.7.5.2 Compaction procedure for soil particle susceptible to crushing**

NOTE. The soil should be considered susceptible to crushing during compaction if the sample contains granular material of a soft nature, e.g. soft limestone, sandstone, etc., which is reduced in size by the action of the vibrating hammer. The procedure described in 3.7.5.2 for soils susceptible to crushing during compaction can be applied to all granular soils if it is convenient to do so.

\* For information on the availability of materials, apply to Enquiry Section, Linford Wood, Milton Keynes MK14 6LE, enclosing a stamped addressed envelope for reply.

**3.7.5.2.1** Weigh, measure and prepare the CBR mould as described in 3.7.5.1.1 and 3.7.5.1.2.

**3.7.5.2.2** Carry out a compaction test on each of the prepared samples in turn as described in 3.7.5.1.3 to 3.7.5.1.9.

**3.7.5.2.3** Discard the remainder of each compacted sample.

**3.7.6** *Calculations, plotting and expression of results* (see form 4.B, appendix A)

**3.7.6.1** Calculate the bulk density,  $\rho$  (in  $\text{Mg}\cdot\text{m}^{-3}$ ), of each compacted specimen from the equation

$$\rho = \left( \frac{m_2 - m_1}{Ah} \right) 1000$$

where

- $m_1$  is the mass of mould and baseplate (in g);
- $m_2$  is the mass of mould, baseplate and compacted soil (in g);
- $h$  is the height of the compacted sample (in mm);
- $A$  is the circular area of the mould (in  $\text{mm}^2$ ).

**3.7.6.2** Calculate the dry density,  $\rho_d$  (in  $\text{Mg}\cdot\text{m}^{-3}$ ), of each compacted specimen from the equation

$$\rho_d = \frac{100\rho}{100 + w}$$

where

- $w$  is the moisture content of the soil (in %).

**3.7.6.3** Plot the dry densities obtained from a series of determinations as ordinates against the corresponding moisture contents as abscissae. Draw a curve of best fit to the plotted points and identify the position of the maximum on this curve. Read off the values of dry density and moisture content, to three significant figures, corresponding to that point. (See figure 6.)

NOTE. The maximum may lie between two observed points but, when drawing the curve, care should be taken not to exaggerate its peak.

**3.7.6.4** On the same graph, plot the curves corresponding to 0 %, 5 % and 10 % air voids, calculated from the equation

$$\rho_d = \frac{1 - \frac{V_a}{100}}{\frac{1 + w}{\rho_s} + \frac{w}{100\rho_w}}$$

where

- $\rho_d$  is the dry density (in  $\text{Mg}\cdot\text{m}^{-3}$ );
- $\rho_s$  is the particle density (in  $\text{Mg}\cdot\text{m}^{-3}$ );
- $\rho_w$  is the density of water (in  $\text{Mg}\cdot\text{m}^{-3}$ ), assumed equal to 1;
- $V_a$  is the volume of air voids in the soil, expressed as a percentage of the total volume of the soil (equal to 0 %, 5 %, 10 % for the purpose of this plot);
- $w$  is the moisture content (in %);

(See figure 6.)

**3.7.7** *Test report.* The test report shall affirm that the test was carried out in accordance with this Part of this standard and shall contain the following information:

- (a) the method of test used;

- (b) the sample preparation procedure, and whether a single sample or separate samples were used;

- (c) the experimental points and the smooth curve drawn through them showing the relationship between moisture content and dry density;

- (d) the dry density corresponding to the maximum dry density on the moisture content/dry density curve reported as the maximum dry density to the nearest 0.01 (in  $\text{Mg}\cdot\text{m}^{-3}$ );

- (e) the percentage moisture content corresponding to the maximum dry density on the moisture content/dry density curve reported as the optimum moisture content to two significant figures;

- (f) the amount of stone retained on the 37.5 mm test sieve reported to the nearest 1 % by dry mass;

- (g) the particle density and whether measured (and if so the method used) or assumed;

- (h) the information required by 9.1 of BS 1377 : Part 1 : 1990.

## 4 Determination of maximum and minimum dry densities for granular soils

### 4.1 General

**4.1.1** *Principle.* An indication of the state of compaction of a cohesionless (free-draining) soil is obtained by relating its dry density to its maximum and minimum possible densities (the limiting densities). The tests described in this section enable these parameters to be determined for cohesionless soils.

**4.1.2** *Types of tests.* Two tests are described for the determination of maximum density, one for sands and one for gravelly soils. In both tests the soil is compacted under water with a vibrating hammer. The test on sands is carried out in a 1 L mould. Gravelly soils are compacted in a CBR mould using a procedure similar to that described in 3.7.

Two tests are described for determination of minimum density. One is a simple dry shaking test for sands and the other is a dropping test for gravelly soils.

The in-situ density can be related to the limiting densities by means of the density index.

### 4.2 Determination of maximum density of sands

**4.2.1** *General.* This test covers the determination of the maximum density to which a clean sand can be compacted. The method is suitable for sands containing a small amount of material passing a 63  $\mu\text{m}$  test sieve, and up to 10 % of fine gravel passing a 6.3 mm test sieve. The soil is compacted into a 1 L mould under water using an electric vibrating hammer.

NOTE 1. Use of a vibrating hammer is appropriate for free-draining soils containing only a small proportion (usually not exceeding 10 % by mass) of material finer than 63  $\mu\text{m}$ , since some fine material is likely to escape from the sample during vibration.

NOTE 2. This test is not applicable to soils containing particles susceptible to crushing when compacted by the vibrating hammer.

The requirements of Part 1 of this standard, where appropriate, shall apply to this test method.

#### 4.2.2 Apparatus

4.2.2.1 *A cylindrical, corrosion-resistant metal mould*, i.e. the 1 L mould, with baseplate and extension, as described in 3.3.2.1.

4.2.2.2 *An electric vibrating hammer* as specified in 3.7.2.2.

NOTE. For safety reasons the vibrating hammer should operate on 110 V, and an earth leakage circuit breaker should be included between the hammer and the mains supply.

4.2.2.3 *A steel tamper* for attachment to the vibrating hammer. Essential dimensions are shown in figure 7(a) which also indicates one suitable design of tamper.

4.2.2.4 *Supporting guide frame* for vibrating hammer (optional).

4.2.2.5 *A watertight container* large enough to hold the compaction mould.

4.2.2.6 *A balance* readable to 1 g.

4.2.2.7 *A straightedge*, e.g. a steel strip about 300 mm long, 25 mm wide, and 3 mm thick, with one bevelled edge.

4.2.2.8 *Test sieves* of aperture sizes 2 mm and 6.3 mm, and receiver.

4.2.2.9 *A palette knife* or spatula.

4.2.2.10 *Large metal tray* with sides about 80 mm deep.

4.2.2.11 *Small metal tray* with sides about 50 mm deep.

4.2.2.12 *A bucket* or similar watertight container.

4.2.2.13 *A small scoop*.

4.2.2.14 *A drying oven* capable of maintaining a temperature of 105 °C to 100 °C.

4.2.2.15 *A stopclock* readable to 1 s.

4.2.2.16 *Apparatus for extracting compacted specimens from the mould* (optional).

4.2.2.17 *A water container* of about 5 L capacity.

4.2.3 *Calibration of vibrating hammer*. The vibrating hammer shall be checked and calibrated as specified in 3.7.3.

#### 4.2.4 Preparation of sample

4.2.4.1 Take enough material from the soil prepared as described in 7.6.4 of BS 1377 : Part 1 : 1990 to enable at least two test samples to be prepared.

4.2.4.2 Sieve the soil on a 6.3 mm test sieve. The retained material may be broken down to sizes between 2 mm and 6.3 mm provided that the total proportion by mass in this size range does not exceed 10 %.

4.2.4.3 Mix the soil thoroughly on the large metal tray and divide into at least two representative portions of about 3 kg each.

4.2.4.4 Pour each prepared sample into warm water in a bucket or suitable container, and stir thoroughly to remove air bubbles.

4.2.4.5 Cover the container and allow to stand for several hours, e.g. overnight, to cool.

#### 4.2.5 Procedure

4.2.5.1 Measure the internal dimensions of the compaction mould to 0.1 mm.

4.2.5.2 Attach the extension to the mould and place the mould assembly in the watertight container on a solid base, e.g. a concrete floor or plinth. Pour water to about 50 mm depth in the mould body, and to the same level in the surrounding container.

4.2.5.3 Add a portion of the soil-water mixture to the mould with the scoop, placing it carefully under the water surface without loss of fines and without segregation of coarse particles. The quantity of sample should be such that the mould is about one-third filled when compacted. Add water to the surrounding container up to the same level as in the mould. Make the soil surface approximately level.

4.2.5.4 Place the circular tamper on the soil and compact with the vibrating hammer for at least 2 min or until there is no further significant decrease in sample height. During this period apply a steady downward force on the hammer so that the total downward force on the sample (including that from the mass of the hammer) is between 300 N and 400 N.

NOTE 1. For safety reasons the vibrating hammer should be protected from water splashing up from the mould and its container.

NOTE 2. The operator can usually judge the required pressure to apply with sufficient accuracy after first carrying out the calibration specified in 3.7.3.4.

NOTE 3. A disc of polyethylene sheet may be placed immediately beneath the tamper plate to prevent sand particles moving up through the annular gap.

4.2.5.5 Repeat 4.2.5.3 and 4.2.5.4 twice more, ensuring that the surface of the sample is always under water. After compaction of the third layer its surface shall be at least level with, but not more than 6 mm proud of, the mould body.

NOTE. The tamper should be removed with care to avoid disturbance of the sand surface by creating suction.

4.2.5.6 Remove the mould containing the soil from the container, clean off any adhering soil from the outside and allow free water to drain from the sample.

4.2.5.7 Remove the extension carefully and trim off the compacted soil level with the top of the mould, using the straightedge. Refill cavities, left by removal of any coarse particles, with finer material, well pressed in.

4.2.5.8 Extract the compacted soil from the mould into the small weighed metal tray, without loss of any soil particles.

4.2.5.9 Dry the soil in an oven at 105 °C to 110 °C, weigh when cool and determine the mass of soil,  $m$  (in g), to 1 g.

4.2.5.10 Repeat 4.2.5.2 to 4.2.5.9 using the second batch of prepared sample.

4.2.5.11 If the dry masses from the two tests differ by more than 50 g, repeat the procedure using fresh samples of the soil.

**4.2.6 Calculations and expression of results**

**4.2.6.1** Calculate the internal volume,  $V$  (in  $\text{cm}^3$ ), of the mould.

**4.2.6.2** Calculate the maximum dry density ( $\rho_{d\text{max}}$ ) of the soil (in  $\text{Mg/m}^3$ ) from the equation

$$\rho_{d\text{max}} = \frac{m}{V}$$

where

$m$  is the greater of the two dry masses of soil compacted into the mould (in g).

Express the result to the nearest  $0.01 \text{ Mg m}^{-3}$ .

**4.2.7 Test report.** The test report shall affirm that the test was carried out in accordance with this Part of this standard and shall contain the following information:

- (a) the method of test used;
- (b) the maximum dry density;
- (c) the percentage of material retained on the 6.3 mm test sieve and whether it was replaced by smaller particles;
- (d) the information required by 9.1 of BS 1377 : Part 1 : 1990.

**4.3 Maximum density of gravelly soils**

**4.3.1 General.** This test covers the determination of the maximum density to which a gravel or sandy gravel can be compacted. The method is suitable for soils passing the 37.5 mm test sieve and containing a small amount of material passing the 63  $\mu\text{m}$  test sieve. The soil is compacted into a 152 mm diameter CBR mould using an electric vibrating hammer.

NOTE 1. Use of a vibrating hammer is appropriate for free-draining soils containing only a small proportion (usually not exceeding 10% by mass) of material finer than 63  $\mu\text{m}$ , since some fine material is likely to escape from the sample during vibration.

NOTE 2. This test is not applicable to soils containing particles susceptible to crushing when compacted by the vibrating hammer.

The requirements of Part 1 of this standard, where appropriate, shall apply to this test method.

**4.3.2 Apparatus**

**4.3.2.1** A cylindrical, corrosion-resistant metal mould, i.e., the CBR mould, as described in 7.2.2.2.

**4.3.2.2** An electric vibrating hammer as specified in 3.7.2.2.

NOTE. For safety reasons the vibrating hammer should operate on 110 V and an earth leakage circuit breaker should be included between the hammer and the mains supply.

**4.3.2.3** A steel tamper for attachment to the vibrating hammer as specified in 3.7.2.3. (See figure 7(b)).

**4.3.2.4** Supporting guide frame for vibrating hammer (optional).

**4.3.2.5** A watertight container large enough to hold the mould.

**4.3.2.6** A balance readable to 5 g.

**4.3.2.7** A straightedge, e.g. a steel strip about 300 mm long, 25 mm wide, and 3 mm thick, with one bevelled edge.

**4.3.2.8** Test sieves, of aperture sizes 37.5 mm and 20 mm and a receiver.

**4.3.2.9** Two corrosion-resistant, metal or plastics trays, with sides, e.g. about 80 mm deep, of a size suitable for the quantity of material to be used.

**4.3.2.10** A bucket, or similar waterproof container.

**4.3.2.11** A scoop.

**4.3.2.12** A drying oven, capable of maintaining a temperature of 105 °C to 110 °C.

**4.3.2.13** A stopclock, readable to 1 s.

**4.3.2.14** Apparatus for extracting compacted specimens from the mould.

**4.3.2.15** A water container, of about 10 L capacity.

**4.3.3 Calibration of vibrating hammer.** The vibrating hammer shall be checked and calibrated as specified in 3.7.3.

**4.3.4 Preparation of sample**

**4.3.4.1** Take enough material from the soil prepared as described in 7.6.4 of BS 1377 : Part 1 : 1990 to enable at least two test samples to be prepared.

**4.3.4.2** Sieve the soil on a 37.5 mm test sieve. The retained material may be broken down to sizes between 20 mm and 6.3 mm provided that the total proportion by mass in this size range does not exceed 30%.

**4.3.4.3** Mix the soil thoroughly and divide into at least two representative portions of about 8 kg each.

**4.3.4.4** Pour each prepared sample into warm water into a bucket or suitable container, and stir thoroughly to remove air bubbles.

**4.3.4.5** Cover the container and allow to stand for several hours, e.g. overnight, to cool.

**4.3.5 Procedure**

**4.3.5.1** Measure the internal dimensions of the mould to 0.5 mm.

**4.3.5.2** Attach the extension to the mould and place the mould assembly in the watertight container on a suitable base, e.g. a concrete floor or plinth. Pour water to about 50 mm depth in the mould body, and to the same level in the surrounding container.

**4.3.5.3** Add a portion of the soil-water mixture to the mould with the scoop, placing it carefully under the water surface without loss of fines and without segregation of coarse particles. The quantity of sample shall be such that the mould is about one-third filled when compacted. Add water to the surrounding container up to the same level as in the mould. Make the soil surface approximately level.

**4.3.5.4** Place the circular tamper on the soil and compact with the vibrating hammer for at least 3 min or until there is no further significant decrease in sample height. During this period apply a steady downward force on the hammer so that the total downward force on the sample (including that from the mass of the hammer) is between 300 N and 400 N.

NOTE 1. For safety reasons the vibrating hammer should be protected from water splashing up from the mould and its container.

NOTE 2. The operator can usually judge the required pressure to apply with sufficient accuracy after first carrying out the calibration described in 3.7.3.4.

NOTE 3. A disc of polyethylene sheet may be placed immediately beneath the tamper plate to prevent sand particles moving up through the annular gap.

4.3.5.5 Repeat 4.3.5.3 and 4.3.5.4 twice, ensuring that the surface of the sample is always under water. After compaction of the third layer its surface shall be at least level with, but not more than 6 mm proud of, the mould body.

NOTE. The tamper should be removed with care to avoid disturbance of the soil surface by creating suction.

4.3.5.6 Remove the mould containing the soil from the container, clean off any adhering soil from the outside and allow free water to drain from the sample.

4.3.5.7 Remove the extension carefully and trim off the compacted soil level with the top of the mould, using the straightedge.

Refill cavities left by removal of any coarse particles with finer material, well pressed in.

4.3.5.8 Extract the compacted soil from the mould into a weighed metal tray, without loss of any soil particles.

4.3.5.9 Dry the soil in an oven at 105 °C to 110 °C, weigh when cool and determine the mass of soil,  $m$  (in g), to 5 g.

4.3.5.10 Repeat 4.3.5.2 to 4.3.5.9 using the second batch of prepared sample.

4.3.5.11 If the dry masses from the two tests differ by more than 150 g, repeat the procedure using fresh samples of the soil.

#### 4.3.6 Calculations and expression of results

4.3.6.1 Calculate the internal volume,  $V$  (in cm<sup>3</sup>), of the mould.

4.3.6.2 Calculate the maximum dry density of the soil,  $\rho_{2max}$  (in Mg/m<sup>3</sup>), from the equation

$$\rho_{2max} = \frac{m}{V}$$

where

$m$  is the greater of the two dry masses of soil compacted into the mould (in g).

Express the result to the nearest 0.01 Mg/m<sup>3</sup>.

4.3.7 *Test report.* The test report shall affirm that the test was carried out in accordance with this Part of this standard and shall contain the following information:

- the method of test used;
- the maximum dry density;
- the percentage of material retained on the 37.5 mm test sieve and whether it was replaced by smaller particles;
- the relevant information required by 9.1 of BS 1377 : Part 1 : 1990.

#### 4.4 Minimum density of sands

4.4.1 *General.* This test covers the determination of the minimum density which a clean, dry sand can sustain. This does not necessarily relate to a state attainable in the field. The method is suitable for sands containing up to about 10 % of fine material passing the 63  $\mu$ m test sieve and with no material retained on the 2 mm test sieve. The dry sand is shaken in a glass cylinder and allowed to fall freely, thereby entrapping air and forming a grain structure enclosing the maximum possible volume of voids.

The requirements of Part 1 of this standard, where appropriate, shall apply to this test method.

#### 4.4.2 Apparatus

4.4.2.1 A 1 L glass measuring cylinder, graduated to 20 mL, preferably without a pouring lip.

4.4.2.2 A rubber bung to fit the cylinder or a piece of rubber membrane and a rubber O-ring to seal its mouth.

4.4.2.3 A balance readable to 1 g.

4.4.2.4 A drying oven capable of maintaining a temperature of 105 °C to 110 °C and complying with 4.2.2.1 of BS 1377 : Part 1 : 1990.

4.4.2.5 A 2 mm test sieve, and receiver.

#### 4.4.3 Preparation of sample

4.4.3.1 Prepare the sand in accordance with 7.6.4 of BS 1377 : Part 1 : 1990 and pass it through a 2 mm test sieve if necessary.

4.4.3.2 Obtain a representative test sample of 1000  $\pm$  1 g.

#### 4.4.4 Procedure

4.4.4.1 Place the weighed sample of sand in the glass cylinder and fit the bung or cover.

4.4.4.2 Shake the cylinder to loosen the sand and invert it a few times.

4.4.4.3 Turn the cylinder upside down, pause until all the sand is at rest, then quickly turn it right way up. Stand the cylinder on a flat surface without jarring it.

4.4.4.4 Record the volume reading ( $V$ ) at the mean level of the surface of the sand to the nearest 10 mL. Avoid shaking or jolting the cylinder during this operation.

4.4.4.5 Repeat 4.4.4.2 to 4.4.4.4 to give at least 10 readings.

4.4.5 *Calculations and expression of results.* Calculate the minimum dry density of the sand,  $\rho_{2min}$  (in Mg/m<sup>3</sup>), from the equation

$$\rho_{2min} = \frac{1000}{V}$$

where

$V$  is the greatest of the 10 or more volume readings recorded (in mL).

Express the result to the nearest 0.01 Mg/m<sup>3</sup>.



**4.4.6 Test report.** The test report shall affirm that the test was carried out in accordance with this Part of this standard and shall contain the following information:

- (a) the method of test used;
- (b) the minimum dry density;
- (c) the percentage of material retained on the 2 mm test sieve;
- (d) the relevant information required by 9.1 of BS 1377 : Part 1 : 1990.

#### 4.5 Minimum density of gravelly soils

**4.5.1 General.** This test covers the determination of the minimum density at which a gravel or sandy gravel can be placed. This method is suitable for gravelly soils passing the 37.5 mm test sieve and containing no more than 10 % of fine material passing the 63  $\mu\text{m}$  test sieve. The soil is allowed to fall freely into a CBR mould, 152 mm in diameter, forming a grain structure enclosing the maximum possible volume of voids.

The requirements of Part 1 of this standard, where appropriate, shall apply to this test method.

##### 4.5.2 Apparatus

**4.5.2.1** A cylindrical, corrosion-resistant, metal mould, i.e. the CBR mould, as described in 7.2.2.2.

**4.5.2.2** A bucket or similar container

**4.5.2.3** A corrosion-resistant, metal or plastics tray with sides, about 80 mm deep, of a size suitable for the quantity of material to be used.

**4.5.2.4** A suitable container, for weighing the sample.

**4.5.2.5** A scoop.

**4.5.2.6** A straightedge, e.g. a steel strip about 300 mm long, 25 mm wide, and 3 mm thick.

**4.5.2.7** A balance, readable to 5 g.

**4.5.2.8** A 37.5 mm test sieve, and a receiver.

**4.5.2.9** A drying oven, capable of maintaining a temperature of 105 °C to 110 °C.

##### 4.5.3 Preparation of sample

**4.5.3.1** Prepare the soil in accordance with 7.6.4 of BS 1377 : Part 1 : 1990 and pass through a 37.5 mm test sieve if necessary.

**4.5.3.2** Take a representative sample, obtained by riffing, at least 50 % larger than the internal volume of the mould.

##### 4.5.4 Procedure

**4.5.4.1** Measure the internal dimensions of the mould to 0.5 mm.

**4.5.4.2** Place the sample in the bucket, and mix to ensure an even distribution of particles of all sizes.

**4.5.4.3** Place the mould, with base and extension attached, on the tray and pour the contents of the bucket steadily from a height of about 0.5 m into the mould, for about 1 s.

**4.5.4.4** Carefully remove the extension and level the surface of the soil to the top of the mould without disturbing the soil in the mould or jarring the mould. Pick off large particles individually by hand, and finally check the surface with the straightedge. A cavity left by the removal of a large particle shall be filled where possible with a single smaller particle.

**4.5.4.5** Empty the contents of the mould into the weighed container and determine the mass of soil,  $m$  (g), to the nearest 5 g.

**4.5.4.6** Remix the soil with the excess remaining on the tray and repeat 4.5.4.2 to 4.5.4.5 to give at least 10 determinations altogether.

##### 4.5.5 Calculations and expression of results

**4.5.5.1** Calculate the internal volume,  $V$  (in  $\text{cm}^3$ ), of the mould.

**4.5.5.2** Calculate the minimum dry density of the soil,  $\rho_{d\text{min}}$  (in  $\text{Mg/m}^3$ ), from the equation

$$\rho_{d\text{min}} = \frac{m}{V}$$

where

$m$  is the lowest of the 10 or more recorded masses of soil placed in the mould (in g).

Express the result to the nearest 0.01  $\text{Mg/m}^3$ .

**4.5.6 Test report.** The test report shall affirm that the test was carried out in accordance with this Part of this standard and shall contain the following information:

- (a) the method of test used;
- (b) the minimum dry density;
- (c) the percentage of material in the original sample retained on the 37.5 mm test sieve;
- (d) the information required by 9.1 of BS 1377 : Part 1 : 1990.

#### 4.6 Derivation of density index

The density index,  $I_D$ , is an index which relates the voids ratio, or dry density, of a soil sample, or of the soil in situ, to the limiting voids ratios, or dry densities, determined as described in 4.2 to 4.5.

If the dry density of the soil in question is denoted by  $\rho_d$ , the density index,  $I_D$ , may be calculated from the equation

$$I_D = \left( \frac{\rho_d - \rho_{d\text{min}}}{\rho_{d\text{max}} - \rho_{d\text{min}}} \right) \left( \frac{\rho_{d\text{max}}}{\rho_d} \right)$$

where

$\rho_{d\text{min}}$  is the dry density at the least dense state;

$\rho_{d\text{max}}$  is the dry density at the densest state.

### 5 Determination of the moisture condition value (MCV)

#### 5.1 General

In the moisture condition test the minimum compactive effort required to produce near-full compaction of a sample of soil passing a 20 mm sieve is determined. The procedures cover the determination of the moisture condition value (MCV) of a

sample of soil and the determination of the variation of MCV with changing moisture content. A rapid procedure for assessing whether or not a sample of soil is stronger than a precalibrated standard is also included.

The requirements of Part 1 of this standard, where appropriate, shall apply to the test methods described in this clause.

## 5.2. Apparatus

**5.2.1** *A moisture condition apparatus*, complete with mould, separating disc and a means of measuring the penetration or protrusion of the rammer to an accuracy of 0.1 mm. The main features are shown in figure 8; other forms of apparatus are acceptable provided the following essential requirements are complied with.

NOTE. The specification for the apparatus is subject to Crown Copyright and is reproduced by permission of the Controller of Her Majesty's Stationery Office. The Secretary of State for Transport has agreed with BSI to make available, through his Transport and Road Research Laboratory, licences to market and manufacture this apparatus on non-exclusive and non-discriminatory terms in the form of royalty payments of 5 %. Applicants for licences should apply to the Director, Transport and Road Research Laboratory, Department of Transport, Old Wokingham Road, Crowthorne, Berks RG11 6AU.

(a) *Frame*. The frame, including the base and guide rods, shall be of robust construction.

The mass of the base shall be at least 31 kg.

A means of positively locating the mould on the base shall be provided.

No special ground or plinth is required so long as the rammer can fall vertically and freely.

(b) *Mould*. The mould cylinder shall be detachable from the mould base and so designed that, when detached, the internal bore shall be uninterrupted throughout its length.

The mould shall be permeable at the base.

NOTE. This can be achieved by making the mould base plug a loose fit within the mould cylinder and providing castellations around the bottom of the mould cylinder.

The permeability shall be such that water discharges from the mould, when maintained at a constant head of 175 mm above the base of the mould, at a rate of between 4 L/min and 7 L/min.

The inner surface of the mould cylinder shall have a protective coating \* at least 0.05 mm thick.

The internal diameter of the mould, before the addition of the coating, shall be between 100.00 mm and 100.10 mm.

The internal height of the mould shall be at least 200 mm.

(c) *Rammer*. The total mass of the rammer, together with the guidance and lifting attachments, shall be 7 kg  $\pm$  50 g. The diameter of the bottom face of the rammer shall be between 96.95 mm and 97.00 mm; no other part of the rammer which enters the mould shall exceed this diameter.

The bottom face of the rammer shall be flat except that fixing and locating devices shall be permissible.

The rammer shall have a guidance system which, while

not impairing the ability to achieve the near free fall requirements, ensures that the rammer does not strike the mould cylinder during the test.

The rammer shall fall freely with minimal friction losses from the guidance system between the release point and the surface of the soil sample in the mould.

The guidance and lifting attachments shall be so designed that the bottom face of the rammer is capable of penetrating to within 35 mm of the bottom of the mould.

A scale shall be provided and attached to the rammer. The scale, in association with a vernier placed on the top surface of the mould cylinder, will allow the penetration of the rammer into the mould to be read to within 0.1 mm. Alternatively, a depth gauge capable of being read to 0.1 mm may be provided to measure the length of rammer protruding above the top of the mould.

A lightweight rigid disc of appropriate material, e.g. fibre, with a diameter between 99.15 mm and 99.20 mm, shall be provided to separate the soil sample in the mould from the bottom face of the rammer.

(d) *Lifting system*. This shall include an automatic latch which engages the rammer lifting attachment at the lower limit of travel, and which releases the rammer at a preset level at the upper limit of travel.

An automatic counter to indicate the number of times that the rammer has been released shall be provided.

(e) *Drop height control*. The position of the rammer release actuator shall be adjustable such that the required height of drop to the surface of the soil sample shall be maintained. The rammer release actuator shall be positively located in any of a number of positions such that the desired height of drop is achieved to within  $\pm$  5 mm.

An indicator system registering the height of drop shall relate the rammer release point to the lower limit of travel of the rammer, i.e. when at rest on the surface of the soil sample.

The height of drop indicator and the height of drop shall be adjustable between 100 mm and 260 mm.

The rammer shall be capable of being released at a height such that the bottom face of the rammer is at least 250 mm above the top of the mould cylinder.

**5.2.2** *A balance* of 2 kg capacity reading to 1 g.

NOTE. For site use, and when the proportion of material retained on the 20 mm sieve is not required to be weighed, a balance readable to 20 g is adequate, e.g. a robust spring balance.

**5.2.3** *A 20 mm test sieve*, and receiver.

**5.2.4** *A corrosion-resistant metal or plastics tray* with sides, e.g. about 80 mm deep, of a size suitable for the quantity of material to be used.

**5.2.5** *Apparatus for extracting specimens from the mould* (optional).

**5.2.6** *Apparatus for the determination of water content*, as described in 3.2 of BS 1377 : Part 2 : 1990.

\* For information on the availability of suitable coatings, apply to Enquiry Section, BSI, Linford Wood, Milton Keynes MK14 6LE, enclosing a stamped addressed envelope for reply.

### 5.3 Checking the moisture condition apparatus

**5.3.1** Before and after a series of tests the apparatus shall be checked and if necessary adjusted as follows.

**5.3.1.1** The rammer shall be capable of dropping freely under the influence of gravity.

**5.3.1.2** The height of drop of the rammer shall be set to 250 mm in accordance with the manufacturer's instructions.

NOTE. A height of drop of 250 mm to the top of the rigid disc is normally used. Occasionally reduced heights of drop may be used to produce a suitable range of MCVs at increased moisture contents. When a height of drop other than 250 mm is used, the height of drop should be clearly stated in the results.

**5.3.1.3** All components of the apparatus shall be secure.

### 5.4 Determination of the MCV of a sample of soil at its natural moisture content

#### 5.4.1 Procedure

**5.4.1.1** Pass the soil through a 20 mm test sieve, break down particle aggregations as necessary, and remove only individual particles coarser than 20 mm. Weigh the removed material to 1 g if the proportion of coarse particles is to be reported.

**5.4.1.2** Take a representative portion of material passing the 20 mm test sieve for determination of the moisture content.

**5.4.1.3** Take a 1.5 kg  $\pm$  20 g sample of soil passing the 20 mm test sieve. The aggregations of soil placed in the mould need not be broken down any further after passing through the 20 mm sieve. Place the soil as loosely as possible in the clean, dry mould (the soil may be pushed into the mould if necessary) and place a separating disc on top of the soil.

NOTE. If the soil is not placed in its loosest condition the reproducibility of the test can be affected. The loose soil condition can be achieved by pouring the soil, either directly into the mould, or through a funnel designed to fit the top of the mould. It should be necessary to push the soil into the mould only if it threatens to overflow the rim of the mould, and then only to such an extent that the final surface of the loose soil is within about 5 mm of the top of the mould.

**5.4.1.4** With the rammer held in the raised position by the retaining pin, locate the mould on the base of the apparatus, and adjust the automatic counter to zero.

**5.4.1.5** Hold the rammer steady and remove the retaining pin. Lower the rammer gently onto the separating disc and allow it to penetrate into the mould under its own weight until it comes to rest. Set the height of drop at  $250 \pm 5$  mm (see note to 5.3.1.2).

**5.4.1.6** Apply one blow of the rammer to the sample by raising the rammer until it is released by the automatic catch. Measure the penetration of the rammer into the mould, or the length of rammer protruding from the mould, to 0.1 mm (see form 4.C of appendix A).

NOTE. The penetration of the rammer into the mould may be read from a scale on the side of the rammer with the aid of a vernier placed on the clean top edge of the mould. Alternatively, the length of rammer above the top edge of the mould may be read using a depth gauge. The latter method has the advantage that the test is more easily performed by one operator. The measured readings determined by either method can be recorded directly in the

appropriate column of the data sheet (see form 4.C of appendix A) and the change in penetration calculated by simple subtraction.

**5.4.1.7** Reset the height of drop to 250 mm.

**5.4.1.8** Repeat 5.4.1.6 and 5.4.1.7, taking readings of penetration or protrusion after a selected accumulated number of blows (see form 4.C of appendix A) and resetting the height of drop to 250 mm as necessary, until no further significant increase in penetration occurs, or until 256 blows have been applied.

NOTE. For a very dry material with a high MCV if more than 256 blows are required the MCV should be reported as 'more than 18'.

**5.4.1.9** Carefully raise the rammer and insert the retaining pin.

**5.4.1.10** Remove the mould from the apparatus, take off its base and extract the specimen.

**5.4.2** Calculations and expression of results (see form 4.C of appendix A).

**5.4.2.1** Calculate the change in penetration between any given number of blows,  $n$ , and four times as many blows (total  $4n$ ; e.g. 1 and 4, 2 and 8, etc.)

**5.4.2.2** Plot the change in penetration, on a linear scale, against the initial number of blows,  $n$ , on a logarithmic scale.

**5.4.2.3** Draw the steepest possible straight line through the points lying immediately before or passing through the 5 mm change in penetration value. The MCV is then defined as  $10 \log B$  (to the nearest 0.1) where  $B$  is the number of blows at which the change in penetration equals 5 mm, as read from the straight line. The MCV may be read directly from the lower horizontal axis if a chart similar to form 4.C of appendix A is used.

NOTE. For most soil types encountered in the UK the relationship between change of penetration and number of blows is of the form shown in figure 9. As the state of full compaction is approached the increasing difficulty in expelling air from the soil causes a reduction in slope of the graph which occasionally extends from above the 5 mm level on the change in penetration axis, indicated by the dashed curve. Such difficulties in expelling air are affected to some extent by the test conditions and will depend on the type of soil. To eliminate the effects of this problem the MCV is determined by drawing the steepest straight line through the points approaching the 5 mm value. However, with certain soil types, mainly granular soils, the change in penetration blows relation may be of the form shown in figure 10. A curve of this form can be considered to have been obtained if the slope of the relation decreases and then increases again before crossing the 5 mm level on the change in penetration axis. The reasons for such a relationship are probably associated with changes additional to the densification of the soil, such as expulsion of water and crushing of soil particles. In such circumstances the steepest straight line cannot be applied, and the number of blows at which the graph crosses the 5 mm value of change in penetration equates to the energy necessary to produce these changes in addition to densification. It is not possible with such soils to determine the MCV relating solely to the densification of the soil in the condition in which it was placed in the mould. Nonetheless, provided appropriate calibrations are made using the same technique, the MCV derived from the best-fit line through the points can be used as a satisfactory method of earthwork suitability control. Where this method is used, it should be clearly stated in the results.

**5.4.2.4** Express the moisture condition value of the soil at natural moisture content to the nearest 0.1 for a laboratory test and to the nearest 0.5 for a field test.

**5.4.3 Test report.** The test report shall affirm that the test was carried out in accordance with this Part of this standard and shall contain the following information:

- (a) the method of test;
- (b) the moisture condition value of the soil;
- (c) the plot of change in penetration against logarithm of the number of blows, if required;
- (d) the proportion of dry mass of any particles larger than 20 mm removed from the initial sample;
- (e) the method of interpretation of the test curve;
- (f) the information required by 9.1 of BS 1377 : Part 1 : 1990.

**5.5 Determination of the MCV/moisture content relation of a soil**

**5.5.1 Procedure**

**5.5.1.1 Soils not susceptible to crushing during compaction**

NOTE. In the case of clay soils which require at least 24 h after mixing with water to ensure uniform distribution of the water, the method for crushable soils (see 5.5.1.2) should be used.

**5.5.1.1.1** Take a sample of about 4 kg of the soil which has been allowed to partially air dry. Do not allow the soil to dry completely before the test.

**5.5.1.1.2** Pass the soil through a 20 mm test sieve, break down particle aggregations as necessary, and remove only individual particles coarser than 20 mm. Weigh the removed material to 1 g if the proportion of coarse particles is to be reported.

**5.5.1.1.3** Take a representative portion of material passing the 20 mm test sieve for determination of the moisture content as described in 3.2 of BS 1377 : Part 2 : 1990.

**5.5.1.1.4** Thoroughly mix the soil passing the 20 mm test sieve with a suitable amount of water.

NOTE. This initial moisture content should be such as to produce a MCV between 13 and 15 (full compaction achieved by 20 to 32 blows of the rammer).

**5.5.1.1.5** Pass the mixed soil through a 20 mm test sieve to break down particle aggregations, and take a 1.5 kg  $\pm$  20 g portion of the sieved soil.

**5.5.1.1.6** Carry out the procedure described in 5.4.1.3 to 5.4.1.9

NOTE. A 1.5 kg sample is normally used. Occasionally reduced sizes of sample may be used to produce a suitable range of MCVs at reduced moisture contents. When the mass of the sample is other than 1.5 kg the mass used should be clearly stated in the results.

**5.5.1.1.7** Remove the mould from the apparatus and take off its base. Extract the specimen from the mould and place it on the tray. Take a representative sample of the specimen and determine its moisture content,  $w$ , as described in 3.2 of BS 1377 : Part 2 : 1990.

**5.5.1.1.8** Break up the remainder of the specimen and mix with the remainder of the original sample. Add a suitable increment of water and mix thoroughly into the sample.

**5.5.1.1.9** Repeat 5.5.1.1.5 to 5.5.1.1.8 for each increment of water added. Make at least four determinations. The range of

moisture contents shall be such that the range of MCVs is approximately 3 to 14.

**5.5.1.2 Soils susceptible to crushing during compaction**

**5.5.1.2.1** Take four or more samples of about 2.5 kg of air-dried soil. Mix each sample thoroughly with a different amount of water to give a suitable range of moisture contents.

NOTE. The range of moisture contents should be such that the range of MCVs is approximately 3 to 14.

**5.5.1.2.2** Prepare and test each sample as described in 5.5.1.1.2, 5.5.1.1.3, 5.5.1.1.6 and 5.5.1.1.7.

**5.5.1.2.3** Discard the remainder of each soil specimen.

**5.5.2 Calculations and expression of results.** Determine the MCV of each specimen and express the result as described in 5.4.2.

Plot the moisture content of each sample against the MCV for the sample and draw the best straight line through the points.

NOTE. In some instances a straight line relationship can be obtained only by ignoring the point or points at the lowest values of moisture content. The moisture condition test can be considered applicable to a soil only if a relation showing an increase in MCV with decreasing moisture content over the expected range of natural moisture contents is obtained. With over-consolidated clays a concave upwards curve is often produced instead of a straight line (assuming that moisture content is plotted on the vertical axis and MCV on the horizontal axis). This is probably caused by variation in the degree to which the clay structure is broken down in the preparation of the samples at different moisture contents. In certain circumstances it may be considered that a non-linear curve is more appropriate as a moisture condition calibration, e.g. as representative of variations in on-site conditions during earthwork construction. A straight line calibration is likely to be achieved if more work is carried out on the soil prior to testing, e.g. by using a more positive mixing method, or by initially raising the moisture content of the soil to a high value (low MCV) before air drying.

**5.5.3 Test report.** The test report shall affirm that the test was carried out in accordance with this Part of this standard and shall contain the following information:

- (a) the method of test;
- (b) the plot of experimental points showing the relationship between moisture content and MCV, with the line of best fit;
- (c) the sample preparation procedure and whether one sample or separate samples were used;
- (d) the proportion by dry mass of particles larger than 20 mm removed from the initial sample;
- (e) the information required by 9.1 of BS 1377 : Part 1 : 1990.

**5.6 Rapid assessment of whether or not a soil is stronger than a precalibrated standard**

**5.6.1 General.** Where the required standard in terms of MCV has been previously determined, the following procedure is an alternative to that described in 5.4 for a rapid assessment of the condition of a soil, e.g. as to its suitability for use in earthwork construction. However, although more rapid than the procedure for determining MCV given in 5.4, it does not determine the degree to which the soil exceeds or fails the precalibrated standard.

### 5.6.2 Procedure

**5.6.2.1** Pass the soil through a 20 mm test sieve, break down particle aggregations as necessary, and remove only individual particles coarser than 20 mm. Weigh the removed material to 1 g.

**5.6.2.2** Take a representative portion of material passing the 20 mm test sieve for determination of the moisture content as described in 3.2 of BS 1377 : Part 2 : 1990.

**5.6.2.3** Take a  $1.5 \text{ kg} \pm 20 \text{ g}$  sample of soil passing the 20 mm test sieve. The aggregations of soil placed in the mould need not be broken down any further after passing through the 20 mm sieve. Place the soil as loosely as possible in the clean, dry mould (the soil may be pushed into the mould if necessary) and place a separating disc on top of the soil. (See note to 5.4.1.3)

**5.6.2.4** Locate the mould in the recess on the base of the apparatus, and adjust the automatic counter to zero.

**5.6.2.5** Hold the rammer steady and remove the retaining pin. Lower the rammer gently onto the separating disc and allow it to penetrate into the mould under its own weight until it comes to rest. Set the height of drop at  $250 \pm 5 \text{ mm}$ .

**5.6.2.6** Apply one blow of the rammer to the sample by raising the rammer until it is released by the automatic catch.

**5.6.2.7** Reset the height of drop to 250 mm.

**5.6.2.8** Apply further blows, resetting the height of drop as necessary, until the total number of blows is equal to that of the MCV equivalent to the precalibrated standard. Measure the penetration of the rammer into the mould, or the length of rammer protruding from the mould, to 0.1 mm.

**5.6.2.9** Apply further blows equal to three times the initial number, without any further adjustment to the height of drop of the rammer. Measure the penetration or protrusion of the rammer as above.

**5.6.2.10** Remove the mould from the apparatus, take off its base, and extract the specimen.

**5.6.3 Calculations and expression of results.** Calculate the difference between the initial and final penetration readings. A difference of more than 5.0 mm indicates that the soil is stronger than the precalibrated standard; a difference of less than 5.0 mm indicates that it is weaker.

Report the difference to two significant figures.

**5.6.4 Test report.** The test report shall affirm that the test was carried out in accordance with this Part of this standard and shall contain the following information:

- (a) the method of test used;
- (b) the difference determined in 5.6.3;
- (c) the soil reported as stronger than the precalibrated standard if that difference is greater than 5 mm, and weaker if less than 5 mm;
- (d) the proportion by dry mass of particles larger than 20 mm removed from the initial sample;
- (e) the information required by 9.1 of BS 1377 : Part 1 : 1990.

## 6 Determination of the chalk crushing value

### 6.1 General

The chalk crushing value (CCV) is determined by using the chalk impact crushing test, which measures the rate at which a sample of chalk lumps crushes under impacts from a free-falling rammer. The chalk crushing value can be used, together with the saturation moisture content of the intact chalk lumps (see 3.3 of BS 1377 : Part 2 : 1990), to classify chalk in relation to its behaviour as a freshly placed fill material.

The test procedure is described for a single sample of chalk lumps, but normal procedure should be to calculate the mean value derived from six such tests on representative samples.

The requirements of Part 1 of this standard, where appropriate, shall apply to this test method.

### 6.2 Apparatus

**6.2.1** A *moisture condition apparatus* complete with accessories, as described in 5.2 and shown in figure 8.

**6.2.2** A *balance* of 2 kg capacity readable to 1 g.

**6.2.3** A *hammer*, for example a 2 lb club hammer.

**6.2.4** *Test sieves*, of aperture sizes 20 mm and 10 mm, and receiver.

**6.2.5** A *metal tray* with sides about 80 mm deep.

**6.2.6** *Apparatus for extracting specimens from the mould* (optional).

### 6.3 Checking the moisture condition apparatus

Before and after a series of tests check the apparatus and if necessary adjust it as described in 5.3.

NOTE. The note to 5.3.1.2 is not relevant to clause 6.

### 6.4 Determination of the chalk crushing value (CCV)

#### 6.4.1 Procedure

**6.4.1.1** Take a  $1 \text{ kg} \pm 20 \text{ g}$  sample of the material passing the 20 mm test sieve and retained on the 10 mm test sieve. Determine the percentage of material retained on the 10 mm test sieve from a sample of appropriate size. Break up lumps of chalk larger than 20 mm using the hammer to provide enough material for the test sample. Take care to exclude coagulated lumps of chalk fines, fragments of flint, and any other non-chalk material.

NOTE. It has been demonstrated experimentally that the chalk crushing value is practically independent of the degree of saturation of the chalk lumps. For this reason the condition of the chalk tested is not specified, although the use of oven-dried chalk should be avoided.

**6.4.1.2** Place the sample loosely in the clean, dry mould and place the separating disc on top of the chalk.

**6.4.1.3** With the rammer held in the raised position by the retaining pin, locate the mould on the base of the apparatus, and adjust the automatic counter to zero.

**6.4.1.4** Hold the rammer steady and remove the retaining pin. Lower the rammer gently on to the separating disc and allow it to penetrate into the mould under its own weight until it comes to rest. Set the height of drop at  $250 \pm 5$  mm.

**6.4.1.5** Apply one blow of the rammer to the sample by raising the rammer until it is released by the automatic catch. Measure the penetration of the rammer into the mould, or the length of rammer protruding from the mould, to 0.1 mm. A suitable form for recording the readings is shown in form 4.D of appendix A.

**NOTE.** The penetration of the rammer into the mould may be read on the scale on the side of the rammer with the aid of a vernier placed on the clean top edge of the mould. Alternatively, the length of rammer above the top edge of the mould may be read using a depth gauge. This latter method has the advantage that the test is more easily performed by one operator. When using the depth gauge method, results should be plotted on the chart shown on form 4.C of appendix A, using a reversed scale on the y-axis.

**6.4.1.6** Reset the height of drop to 250 mm.

**6.4.1.7** Repeat 6.4.1.5 and 6.4.1.6, taking readings of penetration or protrusion after selected accumulated numbers of blows and resetting the height of drop to 250 mm as necessary.

**6.4.1.8** The test shall be deemed to be complete when water starts to ooze from the base of the mould, or no further penetration occurs, or a maximum of 50 blows is reached.

**6.4.1.9** Carefully raise the rammer and insert the retaining pin.

**6.4.1.10** Remove the mould from the apparatus, take off the base and extract the crushed chalk.

**6.4.2** *Calculations and expression of results* (see form 4.D of appendix A)

**6.4.2.1** Plot the penetration or protrusion of the rammer (in mm) on a linear scale against the number of blows on a logarithmic scale.

**6.4.2.2** The greater part of the relation should form a straight line, the slope of which represents the rate at which the chalk was crushed. The chalk crushing value (CCV) is taken as one-tenth of the slope of the straight line.

$$CCV = \frac{Pa - Pb}{10(\text{Log } a - \text{Log } b)}$$

where

*Pa* is the penetration (or protrusion) (in mm) after *a* blows of the rammer as read from the straight line;

*Pb* is the penetration (or protrusion) (in mm) after *b* blows of the rammer as read from the straight line.

Express the CCV as a positive number to two significant figures.

**NOTE.** For ease of calculation use integer values of *a* and *b* such that  $a = 10b$  (e.g.  $a = 20, b = 2$ ; or  $a = 30, b = 3$ ). In these cases  $\log a - \log b = 1$  and

$$CCV = \frac{Pa - Pb}{10}$$

**6.4.3** *Test report.* The test report shall affirm that the test was carried out in accordance with this Part of this standard and shall contain the following information:

- (a) the method of test used;
- (b) the chalk crushing value (CCV);
- (c) the plot of penetration against logarithm of the number of blows, if required;
- (d) the percentage of material in the original sample retained on a 10 mm test sieve;
- (e) the saturation moisture content of the material, when appropriate;
- (f) the information required by 9.1 of BS 1377 : Part 1 : 1990.

## 7 Determination of the California Bearing Ratio (CBR)

### 7.1 General

**7.1.1** *Principle.* This method covers the laboratory determination of the California Bearing Ratio (CBR) of a compacted or undisturbed sample of soil. The principle is to determine the relationship between force and penetration when a cylindrical plunger of a standard cross-sectional area is made to penetrate the soil at a given rate. At certain values of penetration the ratio of the applied force to a standard force, expressed as a percentage, is defined as the California Bearing Ratio (CBR).

The procedure for soaking the specimen, if required, is included.

An in-situ test following the same principle can also be carried out. (See 4.3 of Part 9 of this standard.)

The requirements of Part 1 of this standard, where appropriate, shall apply to the test methods described in this clause.

**7.1.2** *Limitations.* Because of the size of the sample and of the plunger the test is appropriate only for materials having a maximum particle size not exceeding 20 mm. (See 7.2.1.2.)

**7.1.3** *Test conditions.* The following test conditions shall be specified before a test is started.

- (a) The method of preparation of each test specimen.
- (b) The density and moisture content to be achieved, if applicable.
- (c) Whether the test is to be carried out on one end or on both ends of the specimen.
- (d) Whether a test is required on the specimen in the soaked condition.
- (e) The amount of surcharge to be applied to the specimen for the test, and during soaking if applicable.

### 7.2 Preparation of test sample

#### 7.2.1 General

**7.2.1.1** *Methods.* Six methods are described for the preparation of disturbed samples for the CBR test. In methods (1) and (2) static compaction is used to achieve a specified density (see 7.2.3.2 and 7.2.3.3). In the other methods, dynamic compaction by hand or mechanical rammer, or by vibrating hammer, is used, either to achieve a specified

density in methods (3) and (4) (see 7.2.4.2 and 7.2.4.3) or to provide a specified compactive effort in methods (5) and (6) (see 7.2.4.4 and 7.2.4.5). The selection of methods is illustrated in the form of a flow chart in figure 11.

When applying a standard compactive effort the compactive procedures described in 3.4.4, 3.6.4 or 3.7.5 can be used, as appropriate. Alternatively the criterion adopted can be some intermediate degree of compaction.

The preparation of an undisturbed sample for a laboratory CBR test (whether of natural soil or compacted fill) is described in 7.2.5.

**7.2.1.2 Material.** The CBR test shall be carried out on material passing the 20 mm test sieve prepared as described in 7.6.5 of BS 1377 : Part 1 : 1990. If the soil contains particles larger than this the fraction retained on the 20 mm test sieve shall be removed and weighed before preparing the test sample. If this fraction is greater than 25 % the test is not applicable.

The moisture content of the soil shall be chosen to represent the design conditions for which the test results are required. Alternatively, where a range of moisture contents is to be investigated, water shall be added to or removed from the natural soil after disaggregation.

**7.2.1.3 Initial preparation.** The initial soil sample for testing shall be obtained as described in 7.6.1 and 7.6.5 of BS 1377 : Part 1 : 1990. After bringing it to the required moisture content the soil shall be thoroughly mixed and shall normally be sealed and stored for at least 24 h before compaction into the test mould.

NOTE. With cohesionless soils it may be possible to reduce or omit the curing period if trial tests indicate that this has negligible influence on the results.

The mass of soil required for the test shall be calculated or estimated as described in 7.2.1.4, and depends upon the specified conditions and method of preparation.

#### 7.2.1.4 Mass of soil for test

**7.2.1.4.1** When the density or air voids content of a compacted sample is specified the exact amount of soil required for the test can be calculated as described in 7.2.1.4.2 or 7.2.1.4.3. When a compactive effort is specified the mass of soil can only be estimated, as described in 7.2.1.4.4.

**7.2.1.4.2 Dry density specification.** The mass of soil,  $m_1$  (in g), required to just fill the CBR mould of volume  $V_m$  (in  $\text{cm}^3$ ) is given by the equation

$$m_1 = \frac{V_m}{100} (100 + w) \rho_d$$

where

$w$  is the moisture content of the soil (in %); and  
 $\rho_d$  is the specified dry density (in  $\text{Mg/m}^3$ ).

**7.2.1.4.3 Air voids specification.** The dry density,  $\rho_d$  (in  $\text{Mg/m}^3$ ), corresponding to an air voids content of  $V_a$  (in %) is given by the equation

$$\rho_d = \frac{1 - \frac{V_a}{100}}{\frac{1}{\rho_s} + \frac{w}{100 \rho_w}}$$

where

$V_a$  is the air voids expressed as a percentage of the total volume of soil;  
 $\rho_s$  is the particle density (in  $\text{Mg/m}^3$ );  
 $w$  is the soil moisture content (in %);  
 $\rho_w$  is the density of water (in  $\text{Mg/m}^3$ ), assumed equal to 1.

The corresponding mass of soil to just fill the CBR mould is calculated from the equation in 7.2.1.4.2.

**7.2.1.4.4 Compactive effort specification.** About 6 kg of soil shall be prepared for each sample to be tested. The initial mass shall be measured to the nearest 5 g so that the mass used for the test sample can be determined after compaction by difference, as a check.

NOTE. Preliminary trials may be necessary to ascertain the required mass more closely.

## 7.2.2 Apparatus

**7.2.2.1 Test sieves,** of aperture sizes 20 mm and 5 mm.

**7.2.2.2 A cylindrical, corrosion-resistant, metal mould,** i.e. the CBR mould, having a nominal internal diameter of  $152 \pm 0.5$  mm. The mould shall be fitted with a detachable baseplate and a removable extension. The essential dimensions are shown in figures 12 and 13, which also indicate one suitable design of mould. The internal faces shall be smooth, clean and dry before each use.

**7.2.2.3 A compression device for static compaction,** (for methods (1) and (2)). Horizontal platens shall be large enough to cover a 150 mm diameter circle and capable of a separation of not less than 300 mm. The device shall be capable of applying a force of at least 300 kN.

**7.2.2.4 Metal plugs,**  $150 \pm 5$  mm in diameter and  $50 \pm 1.0$  mm thick, for static compaction of a soil specimen (for methods (1) and (2)). A handle which may be screwed into the plugs facilitates removal after compaction. The essential dimensions are shown in figure 13. One is required for method (1) and three are required for method (2).

**7.2.2.5 A metal rammer,** (for methods (3) and (5)). These shall be either the 2.5 kg rammer as specified in 3.3.2, or the 4.5 kg rammer as specified in 3.5.2, depending on the degree of compaction required. A mechanical compacting apparatus may be used provided that it complies with 3.3.2 or 3.5.2.

**7.2.2.6 An electric, vibrating hammer and tamper,** as specified in 3.7.2.2 and 3.7.2.3 (for methods (4) and (6)).

**7.2.2.7 A steel rod,** about 16 mm in diameter and 600 mm long.

**7.2.2.8 A steel straightedge,** e.g. a steel strip about 300 mm long, 25 mm wide and 3 mm thick, with one bevelled edge.

**7.2.2.9 A spatula.**

**7.2.2.10 A balance,** capable of weighing up to 25 kg readable to 5 g.

**7.2.2.11 Apparatus for moisture content determination,** as described in 3.2 of BS 1377 : Part 2 : 1990.

**7.2.2.12 Filter papers,** 150 mm in diameter, e.g. Whatman No. 1 or equivalent.

**7.2.3 Sample preparation by static compression**

**7.2.3.1 General.** Static compression shall be carried out by one of the methods described in 7.2.3.2 and 7.2.3.3 (methods (1) and (2) respectively). Initial preparation of the mould shall be as described in 7.2.3.1.1 to 7.2.3.1.4.

**7.2.3.1.1** Weigh the mould with baseplate attached to the nearest 5 g ( $m_2$ ).

**7.2.3.1.2** Measure the internal dimensions to 0.5 mm.

**7.2.3.1.3** Attach the extension collar to the mould and cover the baseplate with a filter paper.

**7.2.3.1.4** Measure the depth of the collar as fitted, and the thickness of the spacer plug or plugs, to 0.1 mm.

A suitable form for recording data is shown as form 4. E of appendix A.

**7.2.3.2 Method (1). Compression with tamping**

**7.2.3.2.1** Pour the weighed soil slowly into the mould while tamping it with the steel rod. Avoid segregation of particle sizes and ensure that the largest particles are uniformly distributed within the mould.

**7.2.3.2.2** When all the soil is added, level off its surface which should then be about 5 mm to 10 mm above the top of the mould body if the correct amount of tamping has been applied.

**7.2.3.2.3** Place a filter paper on the soil surface, followed by the 50 mm thick spacer plug.

**7.2.3.2.4** Place the mould assembly in the compression device and apply a load to the sample until the top of the plug is flush with the collar. Hold the load constant for at least 30 s.

**7.2.3.2.5** Release the load. If rebound occurs reapply the load for a longer period.

**7.2.3.2.6** Remove the spacer plug, filter paper and collar.

**7.2.3.2.7** Weigh the mould, soil and baseplate to the nearest 5 g ( $m_3$ ).

**7.2.3.2.8** Unless the sample is to be tested immediately, seal the sample (by screwing on the top plate if appropriate) to prevent loss of moisture. With clay soils, or soils in which the air content is less than 5 %, allow the sample to stand for at least 24 h before testing to enable excess pore pressures set up during compression to dissipate.

**7.2.3.3 Method (2). Compression in layers**

**7.2.3.3.1** Divide the prepared quantity of soil into three portions equal to within 50 g and seal each portion in an airtight container until required for use, to prevent loss of moisture.

**7.2.3.3.2** Place one portion of soil in the mould and level the surface.

**7.2.3.3.3** Place the three spacer plugs on top of the soil and compress the soil using the compression device until the thickness of the soil, after removal of the load, is about one-third of the depth of the mould.

NOTE. The correct level of the soil surface can be ascertained easily if the corresponding projection of the top spacer plug above the top of the collar is determined and recorded in advance.

**7.2.3.3.4** Repeat 7.2.3.3.2 and 7.2.3.3.3 using two plugs and then one plug. During the last operation compress the soil until the top surface of the plug is level with the top of the collar.

**7.2.3.3.5** Weigh the mould, soil and baseplate to the nearest 5 g ( $m_3$ ).

**7.2.3.3.6** Seal and store the sample as described in 7.2.3.2.8.

**7.2.4 Sample preparation by dynamic compaction**

**7.2.4.1 General.** Dynamic compaction shall be carried out by one of the methods described in 7.2.4.2 to 7.2.4.5 (methods (3) to (6) respectively).

Initial preparation of the mould shall be as described in 7.2.3.1.

A suitable form for recording data is shown in form 4.E of appendix A.

**7.2.4.2 Method (3). Rammer compaction to a specified density**

**7.2.4.2.1** Divide the prepared quantity of soil into five portions equal to within 50 g and seal each portion in an airtight container until required for use, to prevent loss of moisture.

**7.2.4.2.2** Stand the mould assembly on a solid base, e.g. a concrete floor or plinth.

**7.2.4.2.3** Place the first portion of soil into the mould and compact it using either the 2.5 kg rammer or the 4.5 kg rammer, until the layer occupies about one-fifth of the height of the mould. Ensure that the blows are evenly distributed over the surface. Alternatively the mechanical compacting apparatus may be used.

**7.2.4.2.4** Repeat 7.2.4.2.3 using the other four portions of soil in turn, so that the final level of the fifth layer is just above the top of the mould.

NOTE. Preliminary trials may be necessary to judge the amount of compaction needed for each layer.

**7.2.4.2.5** Remove the collar and trim the soil flush with the top of the mould with the scraper, checking with the steel straightedge.

**7.2.4.2.6** Weigh the mould, soil and baseplate to the nearest 5 g ( $m_3$ ).

**7.2.4.2.7** Seal and store the sample as described in 7.2.3.2.8.

**7.2.4.3 Method (4). Vibrating compaction to a specified density (suitable for granular soils)**

**7.2.4.3.1** Divide the prepared quantity of soil into three portions equal to within 50 g and seal each portion in an airtight container until required for use, to prevent loss of moisture.

**7.2.4.3.2** Stand the mould assembly on a solid base, e.g. a concrete floor or plinth.



**7.3.2.6 Annular surcharge discs**, each having a mass known to  $\pm 50$  g, an internal diameter of 52 mm to 54 mm and an external diameter of 145 mm to 150 mm. Alternatively half-circular segments may be used.

**7.3.2.7 Petroleum jelly.**

**7.3.3. Soaking procedure**

**7.3.3.1** Remove the baseplate from the mould and replace it with the perforated baseplate.

**7.3.3.2** Fit the collar to the other end of the mould, packing the screw threads with petroleum jelly to obtain a watertight joint.

**7.3.3.3** Place the mould assembly in the empty soaking tank. Place a filter paper on top of the sample, followed by the perforated swell plate. Fit the required number of annular surcharge discs around the stem on the perforated plate.

NOTE. One surcharge disc of 2 kg simulates the effect of approximately 70 mm of superimposed construction on the formation being tested. However, the exact amount of surcharge is not critical. Surcharge discs of any convenient multiples may be used.

**7.3.3.4** Mount the dial gauge support on top of the extension collar, secure the dial gauge in place and adjust the stem on the perforated plate to give a convenient zero reading. (See figure 14.)

**7.3.3.5** Fill the immersion tank with water to just below the top of the mould extension collar. Start the timer when the water has just covered the baseplate.

**7.3.3.6** Record readings of the dial gauge at suitable intervals of time, depending on the rate of movement.

**7.3.3.7** Record the time taken for water to appear at the top of the sample. (This may not necessarily indicate the end of the swelling stage.) If this has not occurred within 3 days, flood the top of the sample and leave to soak for a further day, giving the normal soaking period of 4 days. A longer period may be necessary to allow swelling to reach completion.

**7.3.3.8** Plot a graph of swelling (as indicated by the dial gauge movement) against elapsed time or square-root time. Flattening of the curve indicates when swelling is substantially complete.

**7.3.3.9** Take off the dial gauge and its support, remove the mould assembly from the immersion tank and allow the sample to drain for 15 min. If the tank is fitted with a mesh platform leave the mould there to drain after emptying the tank.

**7.3.3.10** Remove the surcharge discs, perforated plate and extension collar. Remove the perforated baseplate and refit the original baseplate.

**7.3.3.11** Weigh the sample with mould and baseplate to the nearest 5 g if the density after soaking is required.

**7.3.3.12** If the sample has swollen, trim it level with the end of the mould and reweigh.

**7.3.3.13** The sample is then ready for test in the soaked condition.

## 7.4 Penetration test procedure

**7.4.1 General.** This subclause describes the procedure for determining the CBR value of the sample prepared by one of the methods described in 7.2 (whether or not it has been soaked as described in 7.3).

**7.4.2 Apparatus**

**7.4.2.1 A cylindrical metal plunger**, the lower end of which shall be of hardened steel and have a nominal cross-sectional area of 1935 mm<sup>2</sup>, corresponding to a specified diameter of  $49.65 \pm 0.10$  mm. A convenient size would be approximately 250 mm long (see figure 15).

**7.4.2.2 A machine for applying the test force through the plunger**, having a means for applying the force at a controlled rate. The machine shall be capable of applying at least 45 kN at a rate of penetration of the plunger of 1 mm/min to within  $\pm 0.2$  mm/min.

**7.4.2.3 A calibrated force-measuring device** complying with 4.2.1.6 of BS 1377 : Part 1 : 1990. The device shall be supported by the crosshead of the compression machine so as to prevent its own weight being transferred to the test specimen.

NOTE. At least three force-measuring devices should be available, having the following ranges.

- 0 to 2 kN readable to 2 N for values of CBR up to 8 %
- 0 to 10 kN readable to 10 N for values of CBR from 8 % to 40 %
- 0 to 50 kN readable to 50 N for values of CBR above 40 %

**7.4.2.4 A means of measuring the penetration of the plunger into the specimen**, to within 0.01 mm. A dial gauge with 25 mm travel, reading to 0.01 mm and fitted to a bracket attached to the plunger is suitable. A general arrangement is shown in figure 15.

NOTE. A dial gauge indicating 1 mm/r is convenient since the specified rate of penetration of 1 mm/min can be controlled conveniently by keeping the hand of the dial gauge in step with the second hand of a clock or watch.

**7.4.2.5 A stopclock or stopwatch** readable to 1 s.

**7.4.2.6 The CBR mould** as described in 7.2.2.2.

**7.4.2.7 Surcharge discs** as described in 7.3.2.6.

**7.4.3 Procedure**

**7.4.3.1** Place the mould with baseplate containing the sample, with the top face of the sample exposed, centrally on the lower platen of the testing machine.

**7.4.3.2** Place the appropriate annular surcharge discs on top of the sample.

**7.4.3.3** Fit into place the cylindrical plunger and force-measuring device assembly with the face of the plunger resting on the surface of the sample.

**7.4.3.4** Apply a seating force to the plunger, depending on the expected CBR value, as follows.

- For CBR value up to 5 % apply 10 N
- For CBR value from 5 % to 30 %, apply 50 N
- For CBR value above 30 % apply 250 N

**7.3.2.6 Annular surcharge discs**, each having a mass known to  $\pm 50$  g, an internal diameter of 52 mm to 54 mm and an external diameter of 145 mm to 150 mm. Alternatively half-circular segments may be used.

**7.3.2.7 Petroleum jelly.**

**7.3.3. Soaking procedure**

**7.3.3.1** Remove the baseplate from the mould and replace it with the perforated baseplate.

**7.3.3.2** Fit the collar to the other end of the mould, packing the screw threads with petroleum jelly to obtain a watertight joint.

**7.3.3.3** Place the mould assembly in the empty soaking tank. Place a filter paper on top of the sample, followed by the perforated swell plate. Fit the required number of annular surcharge discs around the stem on the perforated plate.

NOTE. One surcharge disc of 2 kg simulates the effect of approximately 70 mm of superimposed construction on the formation being tested. However, the exact amount of surcharge is not critical. Surcharge discs of any convenient multiples may be used.

**7.3.3.4** Mount the dial gauge support on top of the extension collar, secure the dial gauge in place and adjust the stem on the perforated plate to give a convenient zero reading. (See figure 14.)

**7.3.3.5** Fill the immersion tank with water to just below the top of the mould extension collar. Start the timer when the water has just covered the baseplate.

**7.3.3.6** Record readings of the dial gauge at suitable intervals of time, depending on the rate of movement.

**7.3.3.7** Record the time taken for water to appear at the top of the sample. (This may not necessarily indicate the end of the swelling stage.) If this has not occurred within 3 days, flood the top of the sample and leave to soak for a further day, giving the normal soaking period of 4 days. A longer period may be necessary to allow swelling to reach completion.

**7.3.3.8** Plot a graph of swelling (as indicated by the dial gauge movement) against elapsed time or square-root time. Flattening of the curve indicates when swelling is substantially complete.

**7.3.3.9** Take off the dial gauge and its support, remove the mould assembly from the immersion tank and allow the sample to drain for 15 min. If the tank is fitted with a mesh platform leave the mould there to drain after emptying the tank.

**7.3.3.10** Remove the surcharge discs, perforated plate and extension collar. Remove the perforated baseplate and refit the original baseplate.

**7.3.3.11** Weigh the sample with mould and baseplate to the nearest 5 g if the density after soaking is required.

**7.3.3.12** If the sample has swollen, trim it level with the end of the mould and reweigh.

**7.3.3.13** The sample is then ready for test in the soaked condition.

## 7.4 Penetration test procedure

**7.4.1 General.** This subclause describes the procedure for determining the CBR value of the sample prepared by one of the methods described in 7.2 (whether or not it has been soaked as described in 7.3).

**7.4.2 Apparatus**

**7.4.2.1** A cylindrical metal plunger, the lower end of which shall be of hardened steel and have a nominal cross-sectional area of 1935 mm<sup>2</sup>, corresponding to a specified diameter of  $49.65 \pm 0.10$  mm. A convenient size would be approximately 250 mm long (see figure 15).

**7.4.2.2** A machine for applying the test force through the plunger, having a means for applying the force at a controlled rate. The machine shall be capable of applying at least 45 kN at a rate of penetration of the plunger of 1 mm/min to within  $\pm 0.2$  mm/min.

**7.4.2.3** A calibrated force-measuring device complying with 4.2.1.6 of BS 1377 : Part 1 : 1990. The device shall be supported by the crosshead of the compression machine so as to prevent its own weight being transferred to the test specimen.

NOTE. At least three force-measuring devices should be available, having the following ranges.

- 0 to 2 kN readable to 2 N for values of CBR up to 8 %
- 0 to 10 kN readable to 10 N for values of CBR from 8 % to 40 %
- 0 to 50 kN readable to 50 N for values of CBR above 40 %

**7.4.2.4** A means of measuring the penetration of the plunger into the specimen, to within 0.01 mm. A dial gauge with 25 mm travel, reading to 0.01 mm and fitted to a bracket attached to the plunger is suitable. A general arrangement is shown in figure 15.

NOTE. A dial gauge indicating 1 mm/r is convenient since the specified rate of penetration of 1 mm/min can be controlled conveniently by keeping the hand of the dial gauge in step with the second hand of a clock or watch.

**7.4.2.5** A stopclock or stopwatch readable to 1 s.

**7.4.2.6** The CBR mould as described in 7.2.2.2.

**7.4.2.7** Surcharge discs as described in 7.3.2.6.

**7.4.3 Procedure**

**7.4.3.1** Place the mould with baseplate containing the sample, with the top face of the sample exposed, centrally on the lower platen of the testing machine.

**7.4.3.2** Place the appropriate annular surcharge discs on top of the sample.

**7.4.3.3** Fit into place the cylindrical plunger and force-measuring device assembly with the face of the plunger resting on the surface of the sample.

**7.4.3.4** Apply a seating force to the plunger, depending on the expected CBR value, as follows.

- For CBR value up to 5 % apply 10 N
- For CBR value from 5 % to 30 %, apply 50 N
- For CBR value above 30 % apply 250 N

Record the reading of the force-measuring device as the initial zero reading (because the seating force is not taken into account during the test) or reset the force-measuring device to read zero.

**7.4.3.5** Secure the penetration dial gauge in position. Record its initial zero reading, or reset it to read zero.

**7.4.3.6** Start the test so that the plunger penetrates the sample at a uniform rate of  $1 \pm 0.2$  mm/min, and at the same instant start the timer.

**7.4.3.7** Record readings of the force gauge at intervals of penetration of 0.25 mm, to a total penetration not exceeding 7.5 mm (see form 4.F of appendix A).

NOTE. If the operator plots the force penetration curve as the test is being carried out, the test can be terminated when the indicated CBR value falls below its maximum value. Thus if the CBR at 2.5 mm were seen to be 6 % but by 3.5 mm penetration it could be seen to have fallen below 6 %, the test could be stopped and the result reported as:

CBR at 2.5 mm penetration = 6 %

CBR at 5.0 mm penetration = < 6 %

**7.4.3.8** If no further test is to be made on the sample, proceed to 7.4.3.13.

**7.4.3.9** If a test is to be carried out on both ends of the sample, raise the plunger and level the surface of the sample by filling in the depression left by the plunger and cutting away any projecting material. Check for flatness with the straightedge.

**7.4.3.10** Remove the baseplate from the lower end of the mould, fit it securely on the top end and invert the mould. Trim the exposed surface if necessary.

**7.4.3.11** If the sample is to be soaked before carrying out a test on the base follow the procedure described in 7.3.3 and then proceed to 7.4.3.12.

**7.4.3.12** Carry out the test on the base by repeating 7.4.3.1 to 7.4.3.8.

**7.4.3.13** After completing the penetration test or tests, determine the moisture content of the test sample as follows.

(a) For a cohesive soil containing no gravel-sized particles, take a sample of about 350 g from immediately below each penetrated surface, but do not include filling material used to make up the first end tested. Determine the moisture content of each sample as described in 3.2 of BS 1377 : Part 2 : 1990.

NOTE. If the sample has been soaked the moisture content after soaking will generally exceed the initial moisture content. Because of the possibility of moisture gradients the determination of dry density from the moisture content after soaking may have little significance. If required, the dry density after soaking can be calculated from the initial sample mass and moisture content and the measured increase in height due to swelling.

(b) For a cohesionless soil or a cohesive soil containing gravel-sized particles, extrude the sample, break in half and determine the moisture contents of the upper and lower halves separately using the procedure described in 3.2 of BS 1377 : Part 2 : 1990.

## 7.5 Calculation and plotting

**7.5.1** Force-penetration curve (see forms 4.F and 4.G of appendix A)

**7.5.1.1** Calculate the force applied to the plunger from each reading of the force-measuring device observed during the penetration test.

NOTE. Alternatively, readings of the force-measuring device may be plotted directly against penetration readings. Forces are then calculated only at the appropriate penetration values as in 7.5.2 (after correction if necessary).

**7.5.1.2** Plot each value of force as ordinate against the corresponding penetration as abscissa and draw a smooth curve through the points.

The normal type of curve is convex upwards as shown by the curve labelled test 1 in figure 16, and needs no correction.

If the initial part of the curve is concave upwards as for test 2 (curve OST) in figure 16, the following correction is necessary. Draw a tangent at the point of greatest slope, i.e. the point of inflexion, *S*, and produce it to intersect the penetration axis at *Q*. The corrected curve is represented by *QST*, with its origin at *Q* from which a new penetration scale can be marked.

If the graph continues to curve upwards as for test 3 in figure 16, and it is considered that the penetration of the plunger is increasing the soil density and therefore its strength, the above correction is not applicable.

**7.5.2** Calculation of California Bearing Ratio. The standard force-penetration curve corresponding to a CBR value of 100 % is shown by the heavy curve in figure 17, and forces corresponding to this curve are given in table 3. The CBR value obtained from a test is the force read from the test curve (after correction and calculation if necessary) at a given penetration expressed as a percentage of the force corresponding to the same penetration on the standard curve. Curves representing a range of CBR values are included in figure 17.

Penetrations of 2.5 mm and 5 mm are used for calculating the CBR value. From the test curve, with corrected penetration scale if appropriate, read off the forces corresponding to 2.5 mm and 5 mm penetration. Express these as a percentage of the standard forces at these penetrations, i.e. 13.2 kN and 20 kN respectively. Take the higher percentage as the CBR value.

If the force-penetration curve is plotted on a diagram similar to figure 17, the CBR value at each penetration can be read directly without further computation if the correction described in 7.5.1.2, for test 2 is not required. The same diagram can be used for small forces and low CBR values if both the force scale (ordinate) and the labelled CBR values (abscissa) are divided by 10 as shown in brackets in figure 17.

**Table 3. Standard force-penetration relationships for 100 % CBR**

Penetration	Force
mm	kN
2	11.5
2.5	13.2
4	17.6
5	20.0
6	22.2
8	26.3

**7.5.3 Density calculations**

**7.5.3.1** Calculate the internal volume of the mould,  $V_m$  (in  $\text{cm}^3$ ).

**7.5.3.2 Bulk density.** The initial bulk density,  $\rho$  (in  $\text{Mg/m}^3$ ), of a sample compacted with a specified effort (preparation methods (5) and (6); see 7.2.4.4 and 7.2.4.5), or of an undisturbed sample, is calculated from the equation

$$\rho = \frac{m_3 - m_2}{V_m}$$

where

$m_3$  is the mass of soil, mould and baseplate (in g);

$m_2$  is the mass of the mould and baseplate (in g);

$V_m$  is the volume of the mould body (in  $\text{cm}^3$ ).

**7.5.3.3 Dry density.** The initial dry density,  $\rho_d$  (in  $\text{Mg/m}^3$ ), of the sample is calculated from the equation

$$\rho_d = \left( \frac{100}{100 + w} \right) \rho$$

where

$w$  is the moisture content of the soil (in %).

If the dry density,  $\rho_{dS}$  (in  $\text{Mg/m}^3$ ), of the soaked soil is required, calculate it from the equation

$$\rho_{dS} = \frac{\rho_d}{1 + \frac{Ax}{1000 V_m}}$$

where

$A$  is the area of cross section of the mould (in  $\text{mm}^2$ )

$x$  is the increase in sample height after swelling (in mm).

**7.6 Test report**

The test report shall affirm that the test was carried out in accordance with this Part of this standard. The results of tests on the top and bottom ends of the sample shall be indicated separately.

The test report shall contain the following information:

- (a) the method of test used;
- (b) force-penetration curves, showing corrections if appropriate;
- (c) the California Bearing Ratio (CBR) values, to two significant figures. If the results from each end of the sample are within  $\pm 10\%$  of the mean value, the average result may be reported;
- (d) the initial sample density and the moisture content and dry density if required;
- (e) the method of sample preparation;
- (f) the moisture contents below the plunger at the end of each test, or the final moisture contents of the two halves of the sample;
- (g) whether soaked or not, and if so the period of soaking, the amount of swell and the swelling-time curve (if required);
- (h) the proportion by dry mass of any over-size material removed from the original soil sample before testing;
- (i) the information required by 9.1 of BS 1377 : Part 1 : 1990.

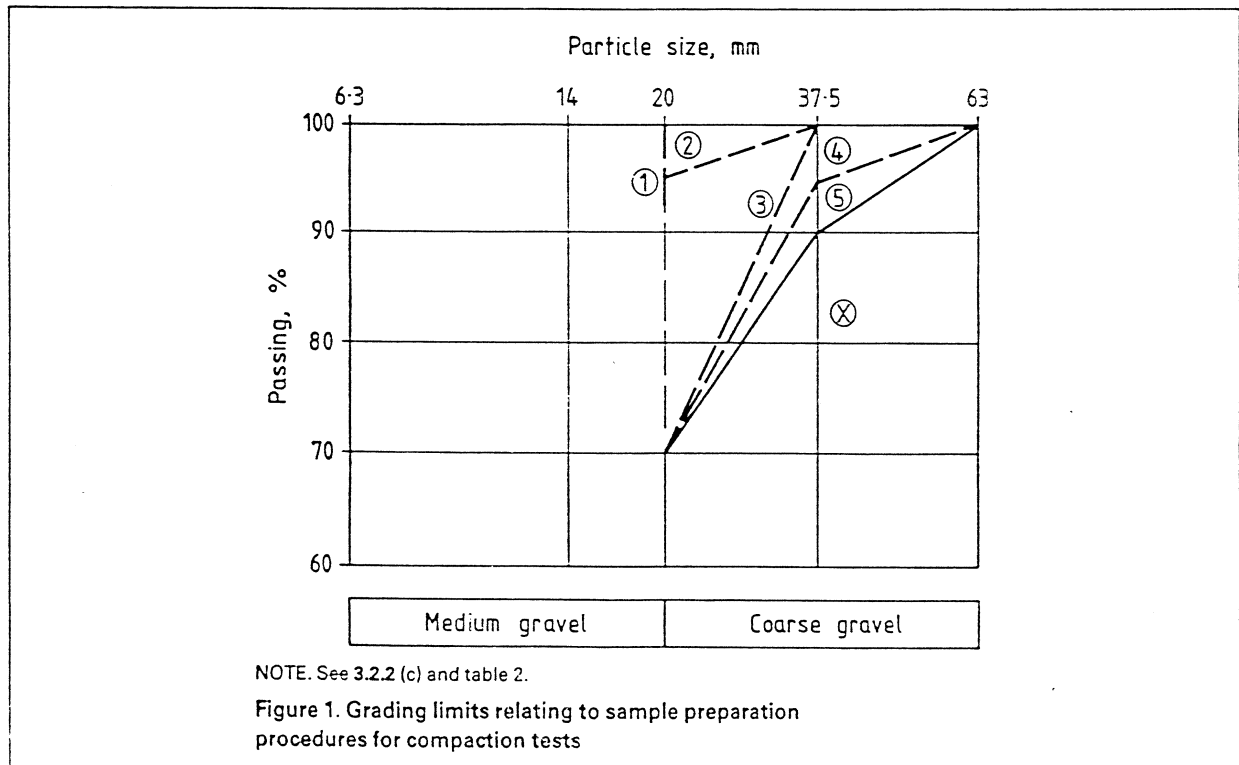

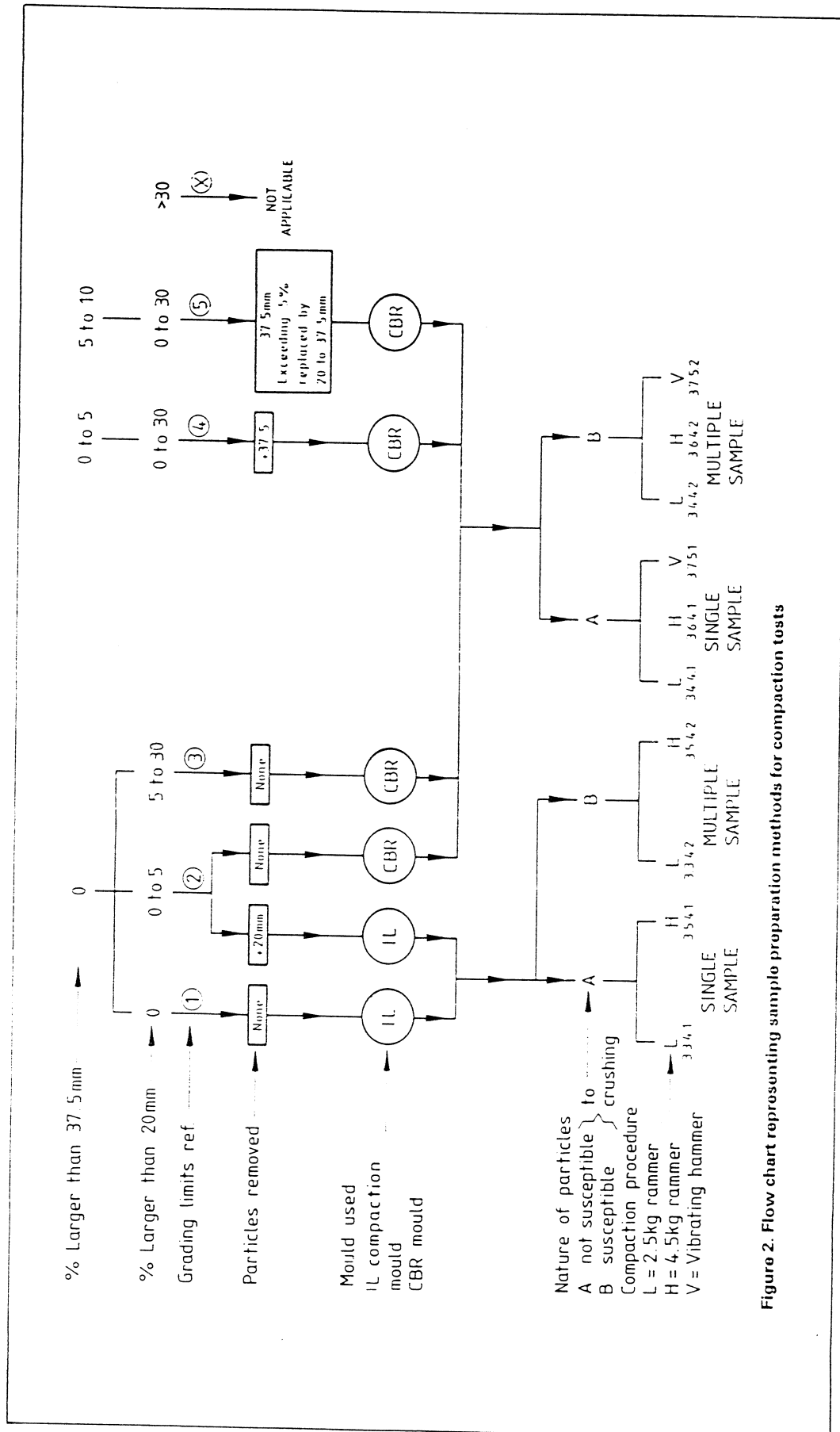
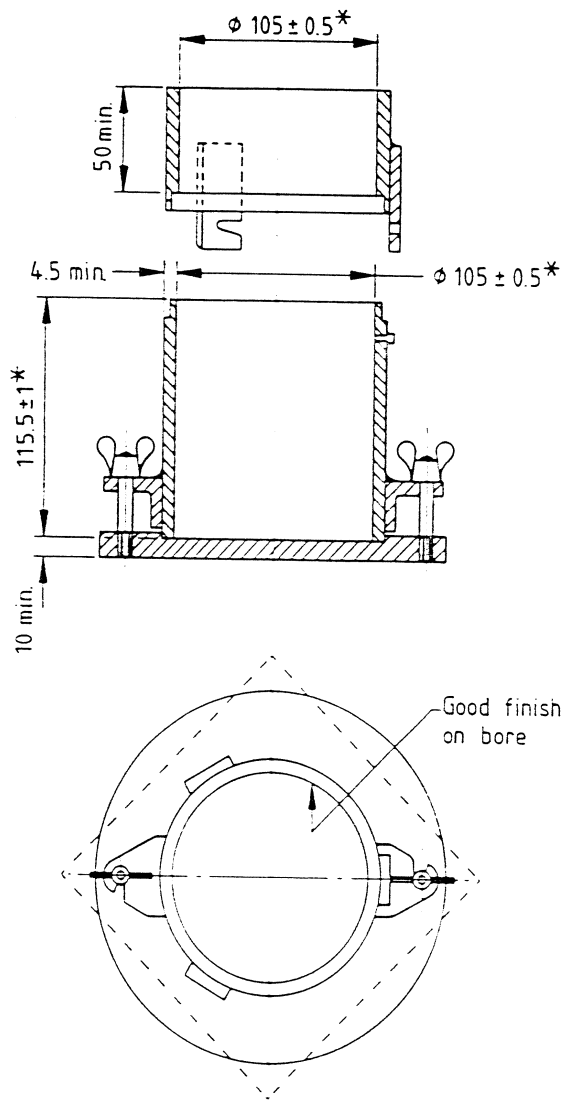

Figure 2. Flow chart representing sample preparation methods for compaction tests



All dimensions shown are in millimetres.

This design has been found satisfactory, but alternative designs may be used provided that the essential requirements are fulfilled.

\*See 4.1.3.1.1 of BS 1377 : Part 1 : 1990.

Figure 3. Mould for compaction test (1 L mould)

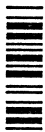

454

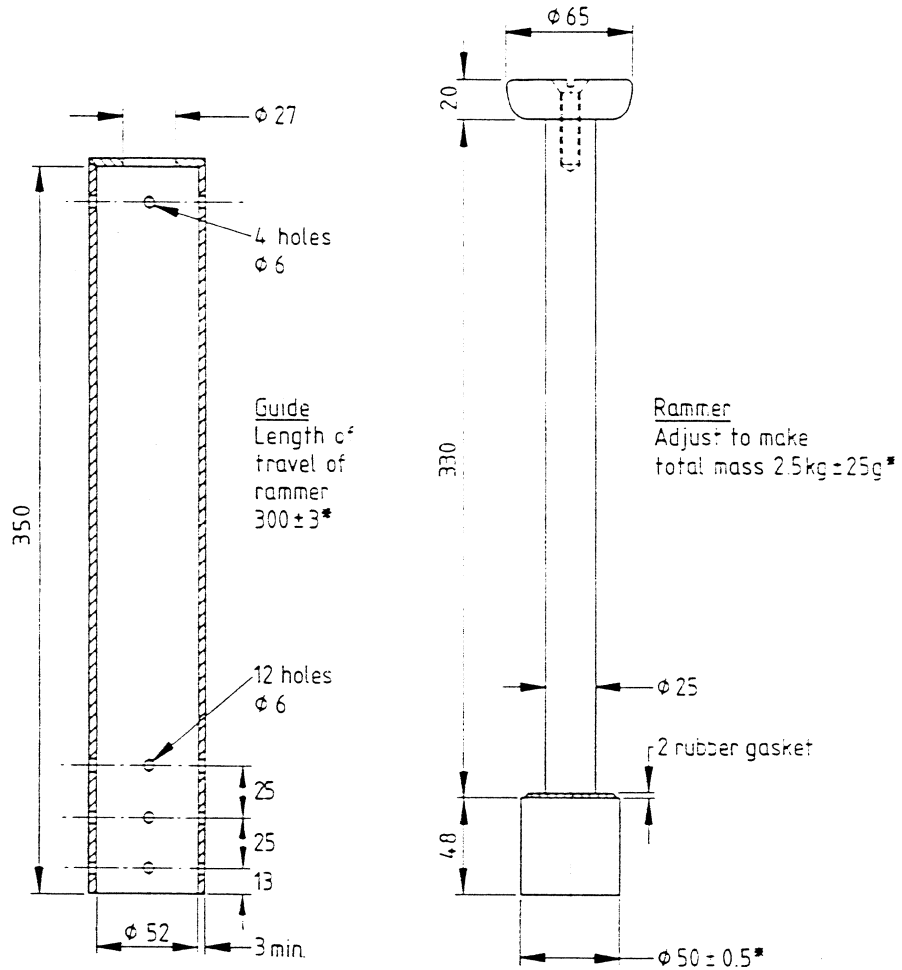

All dimensions shown are in millimetres.

This design has been found satisfactory, but alternative designs may be used provided that the essential requirements are fulfilled.

\*See 4.1.3.1.1 of BS 1377 : Part 1 : 1990.

Figure 4. 2.5 kg rammer for compaction test

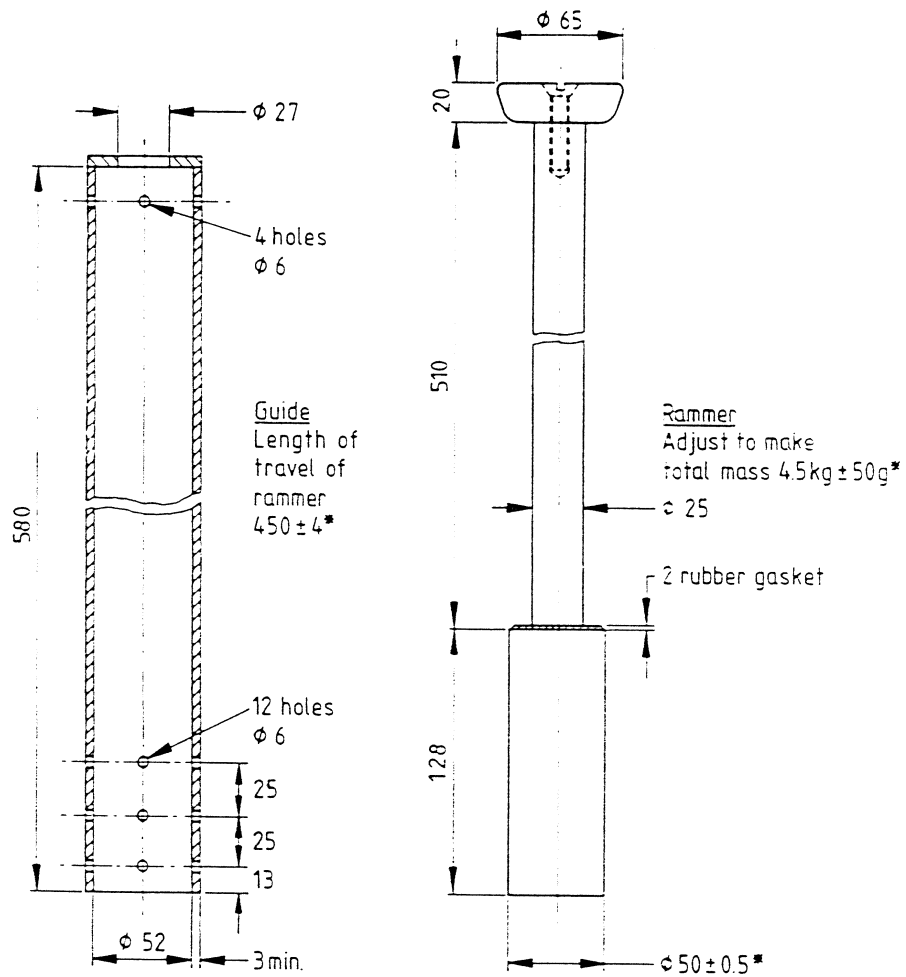

This design has been found satisfactory, but alternative designs may be used provided that the essential requirements are fulfilled.

\*See 4.1.3.1.1 of BS 1377 : Part 1 : 1990.

Figure 5. 4.5 kg rammer for compaction test



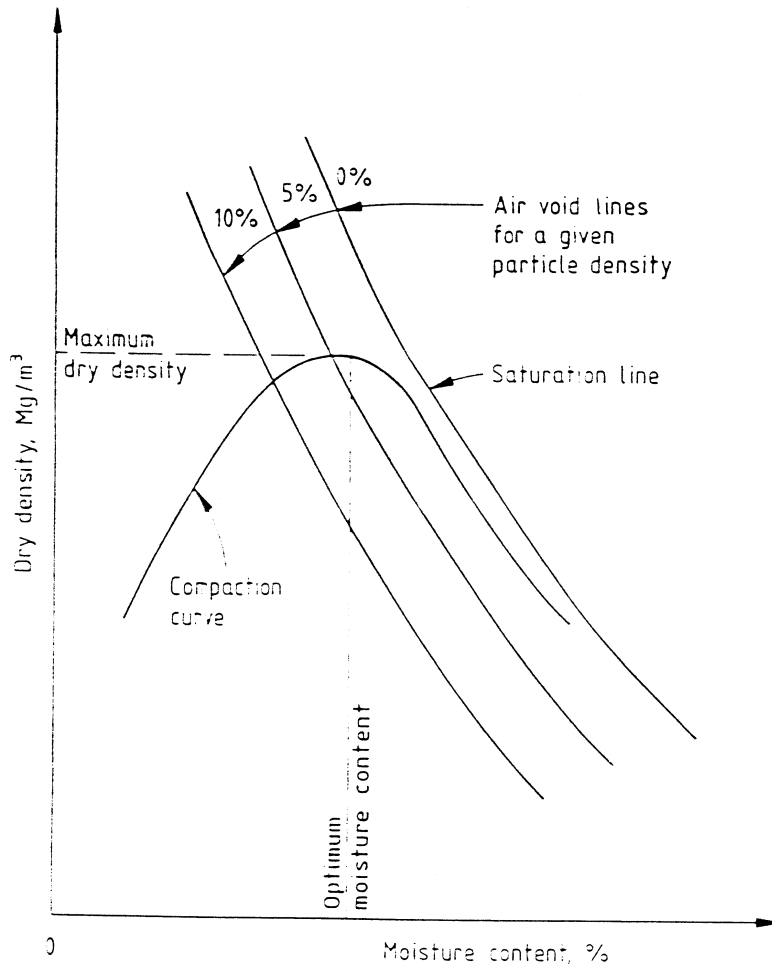
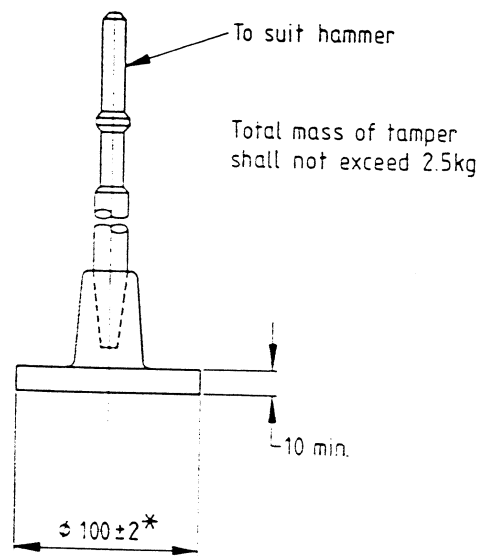
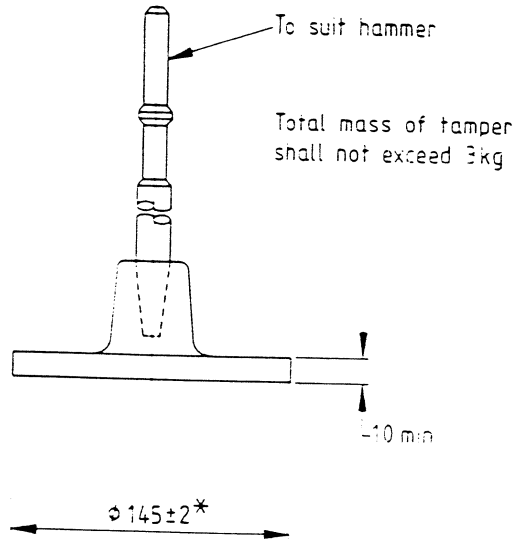

Figure 6. Dry density/moisture content relationship curve

(a) For use with the  
1L compaction mould



(b) For use with the  
CBR mould



\*See 4.1.3.1.1 of BS 1377 : Part 1 : 1990.

All dimensions shown are in millimetres.

Figure 7. Tampers for vibrating hammer compaction test

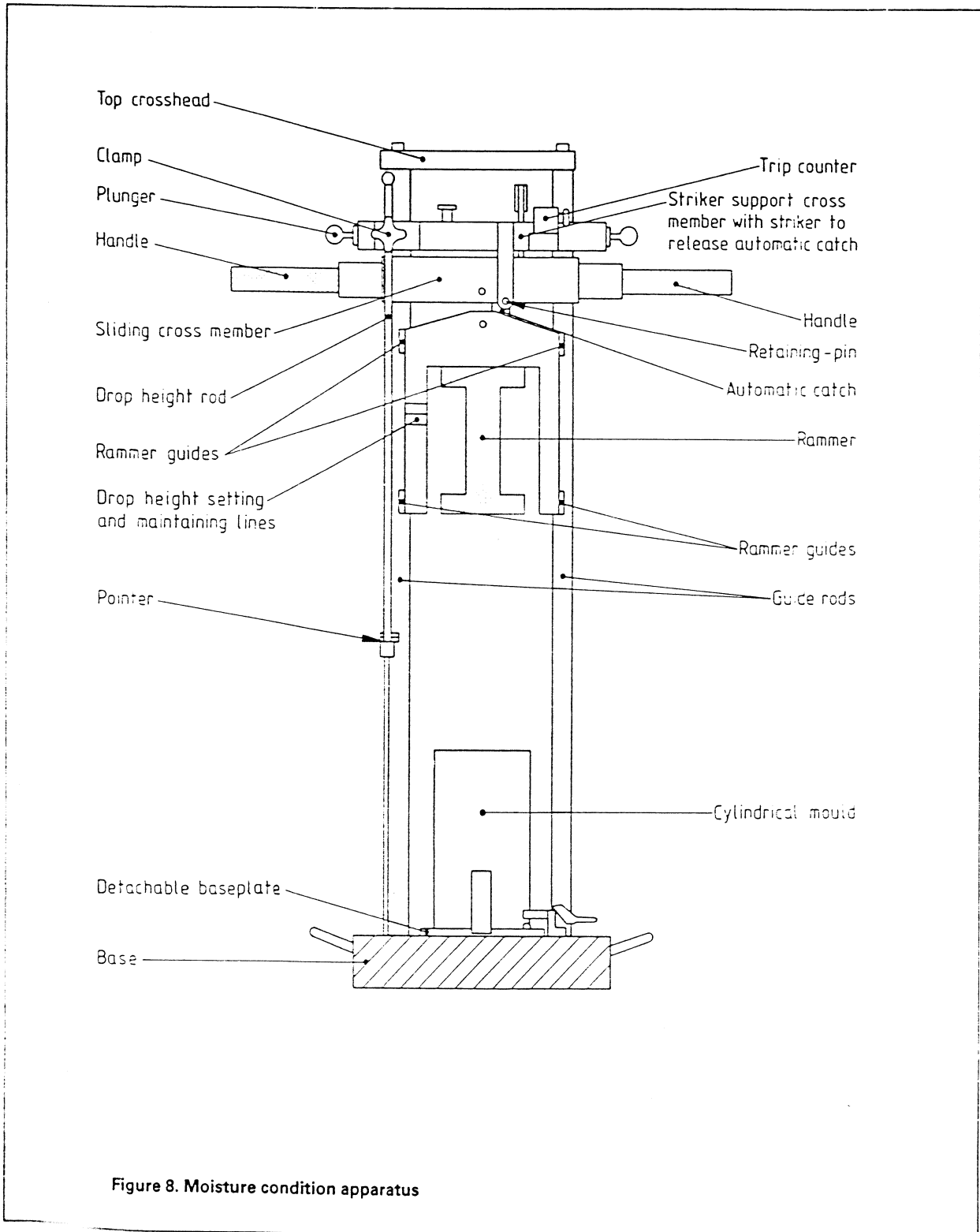
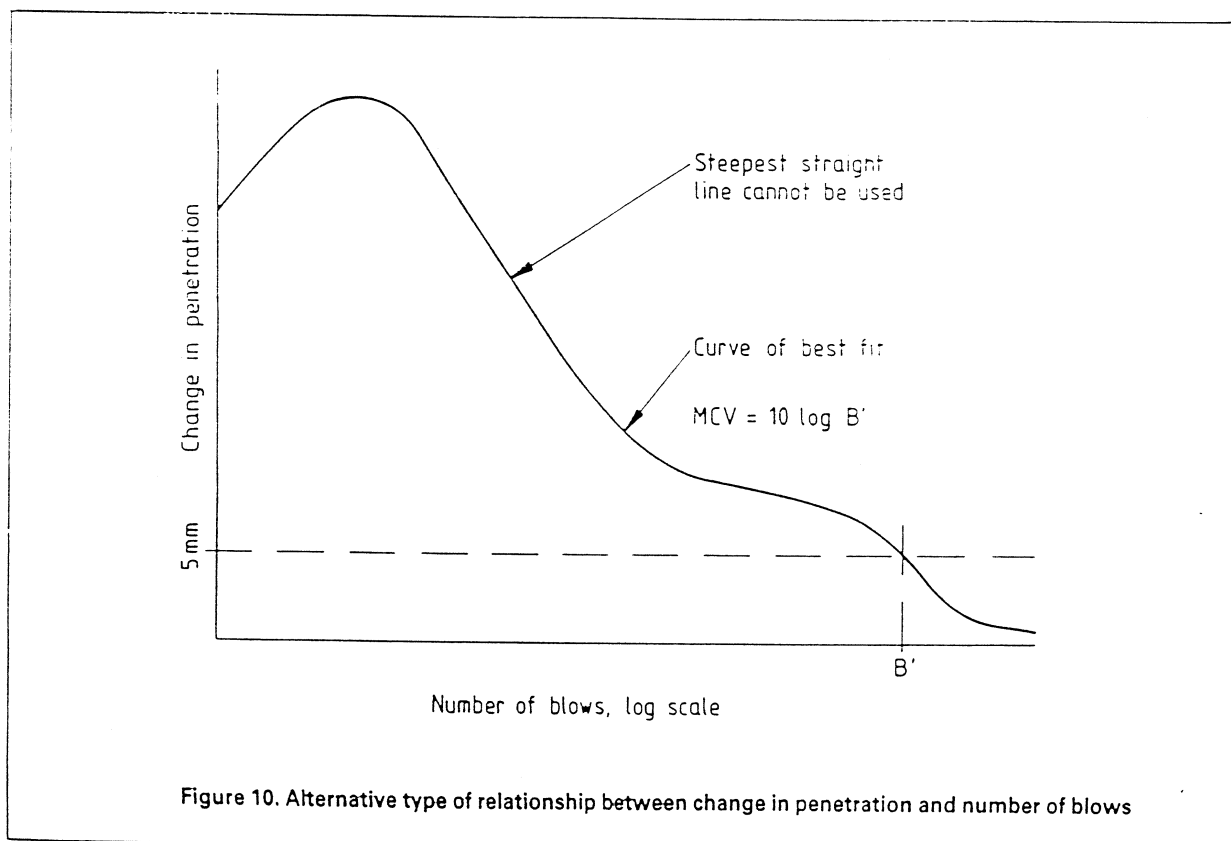
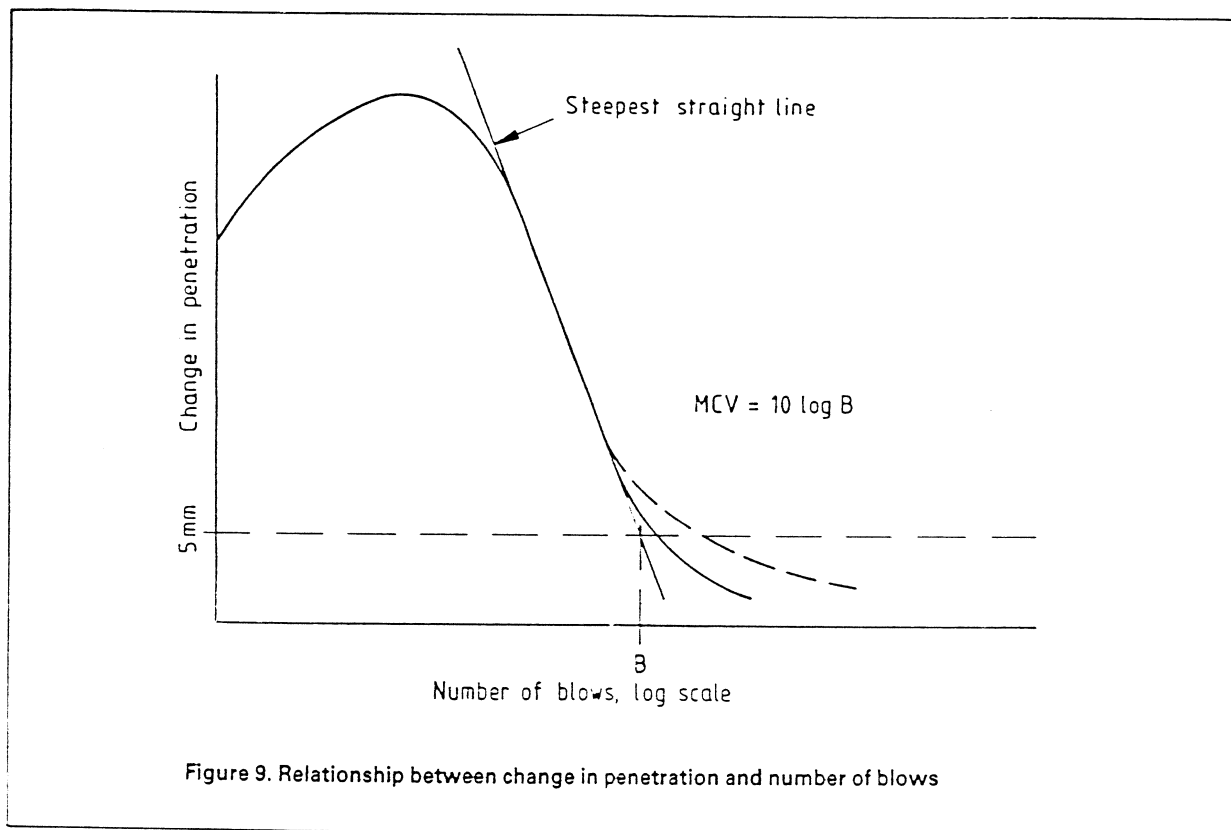

Figure 8. Moisture condition apparatus



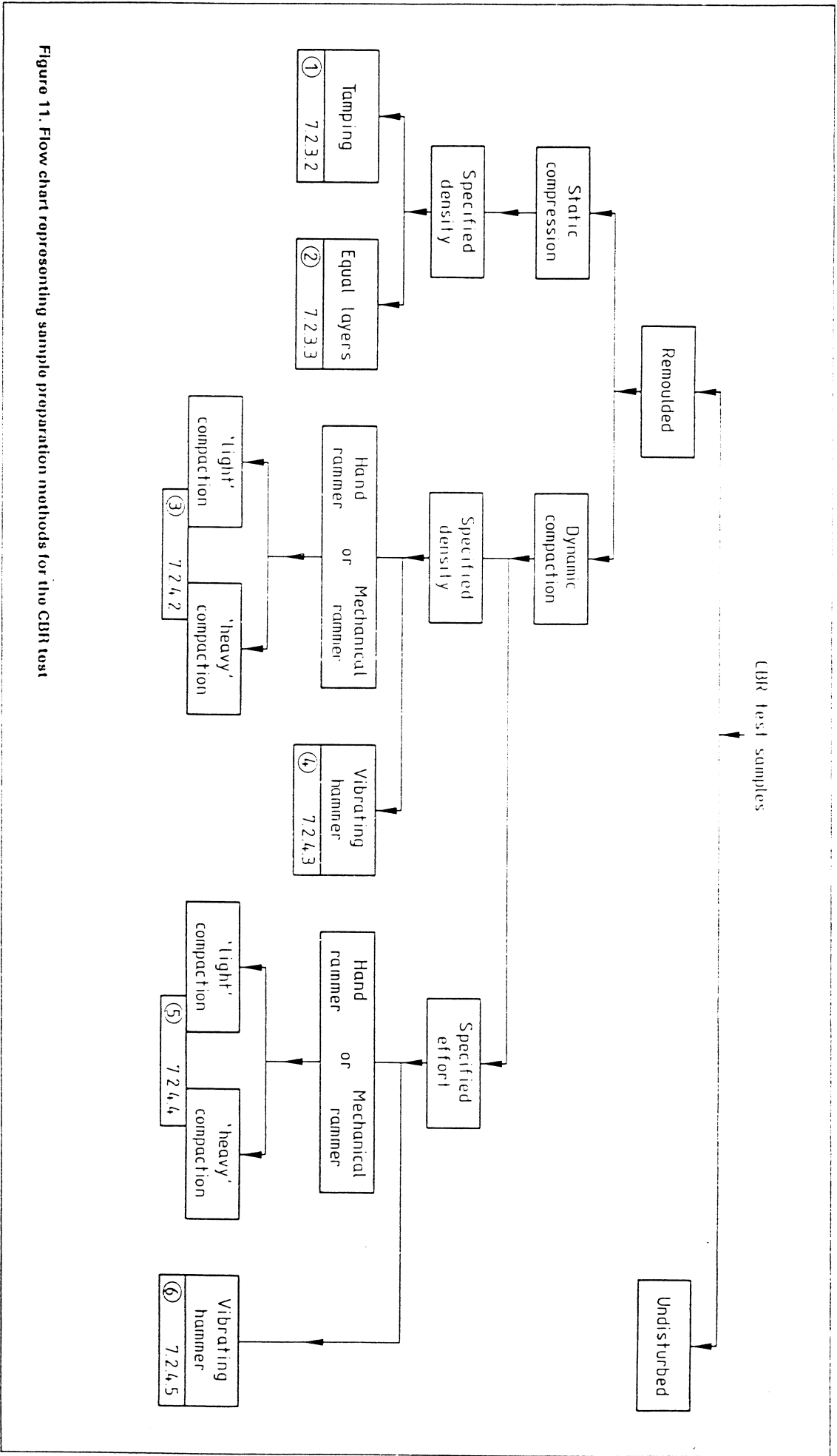
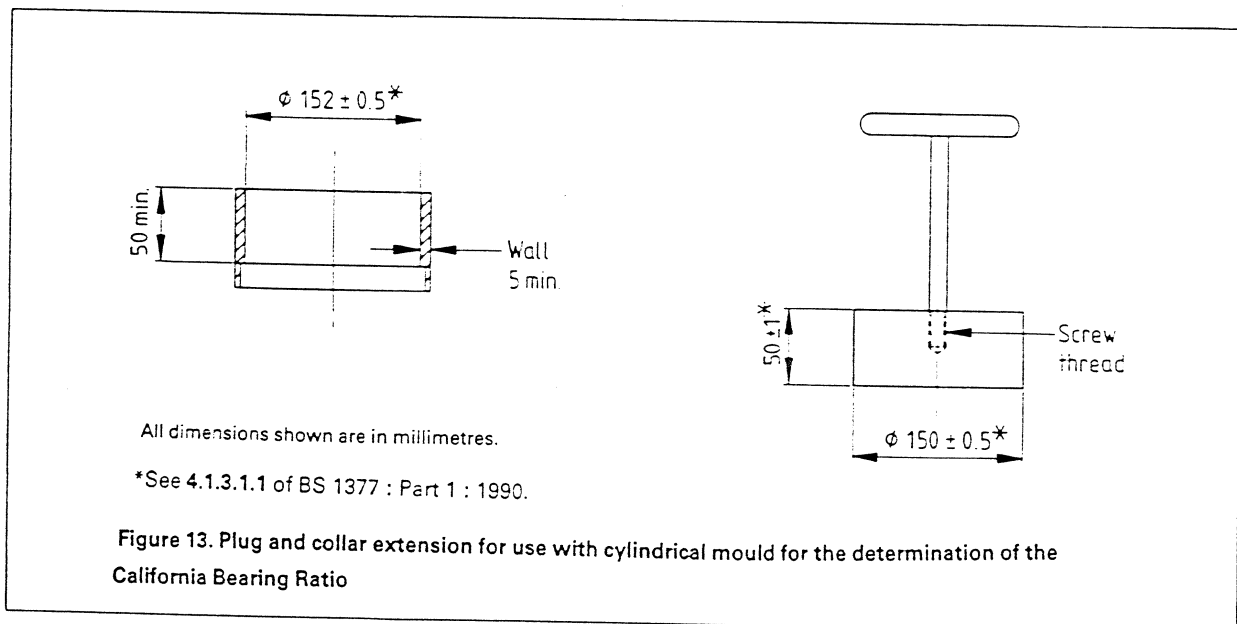
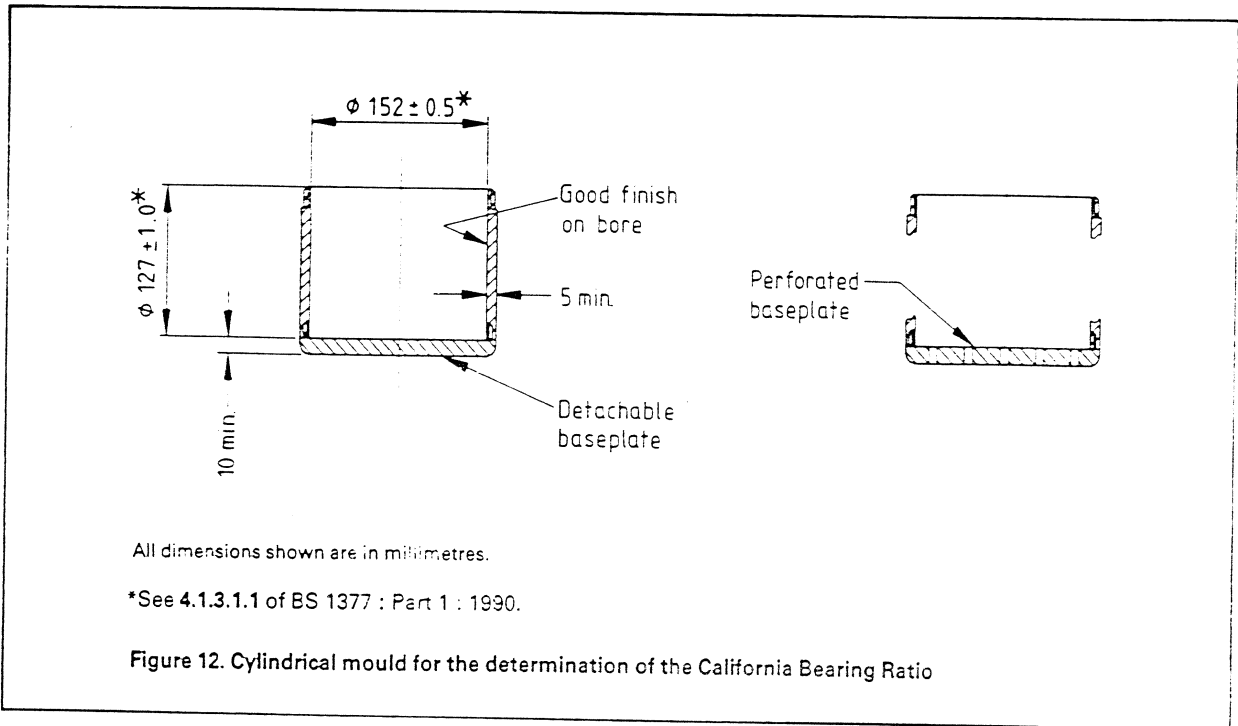

Figure 11. Flow chart representing sample preparation methods for the CBR test



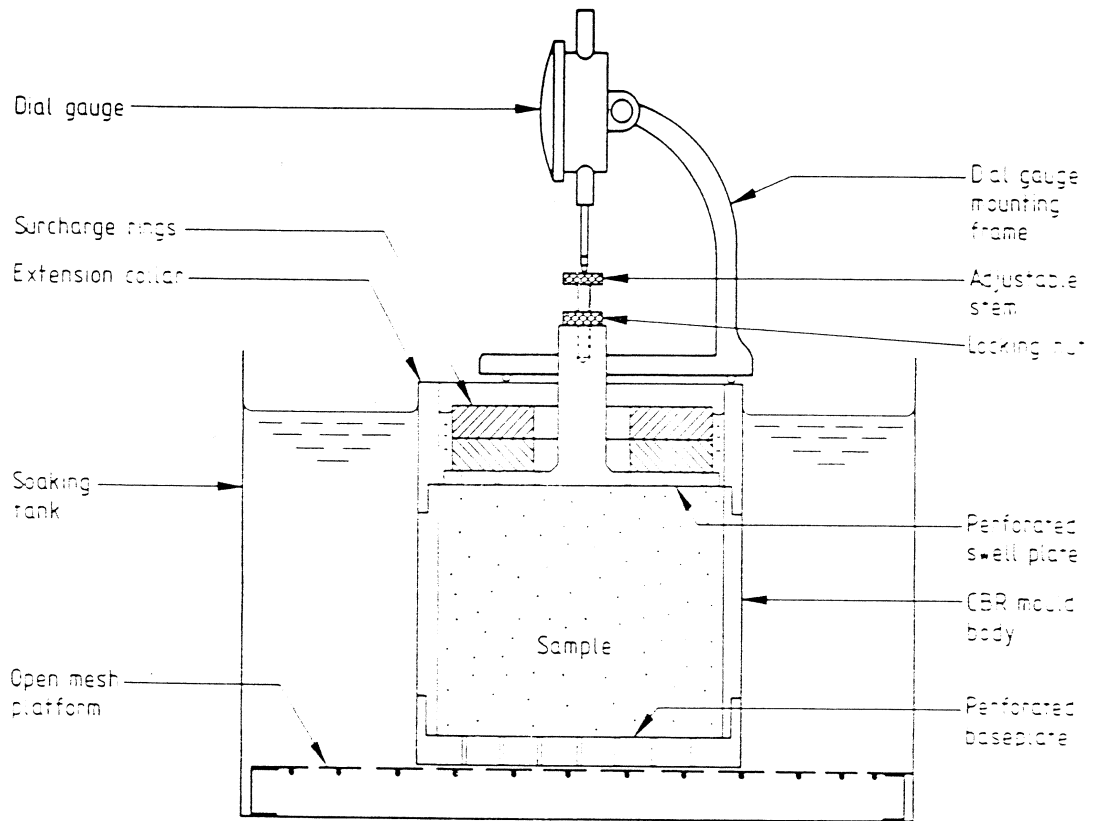
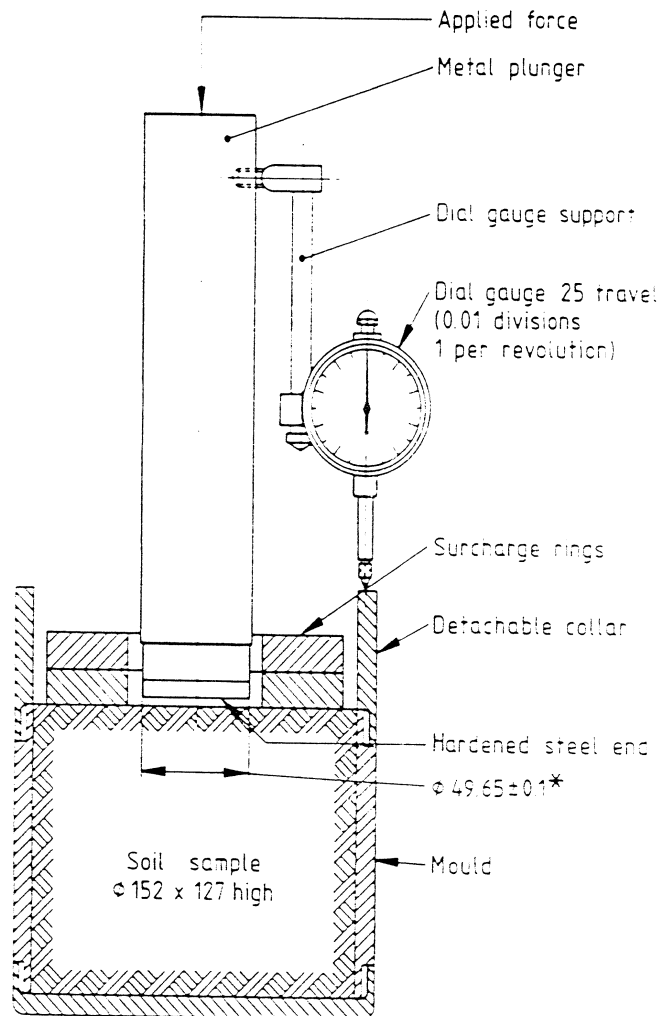

Figure 14. Apparatus for measuring the swelling of a sample during soaking for the CBR test





All dimensions shown are in millimetres.

This design has been found satisfactory, but alternative designs may be used provided that the essential requirements are fulfilled.

\*See 4.1.3.1.1 of BS 1377 : Part 1 : 1990.

Figure 15. General arrangement of apparatus for the CBR test



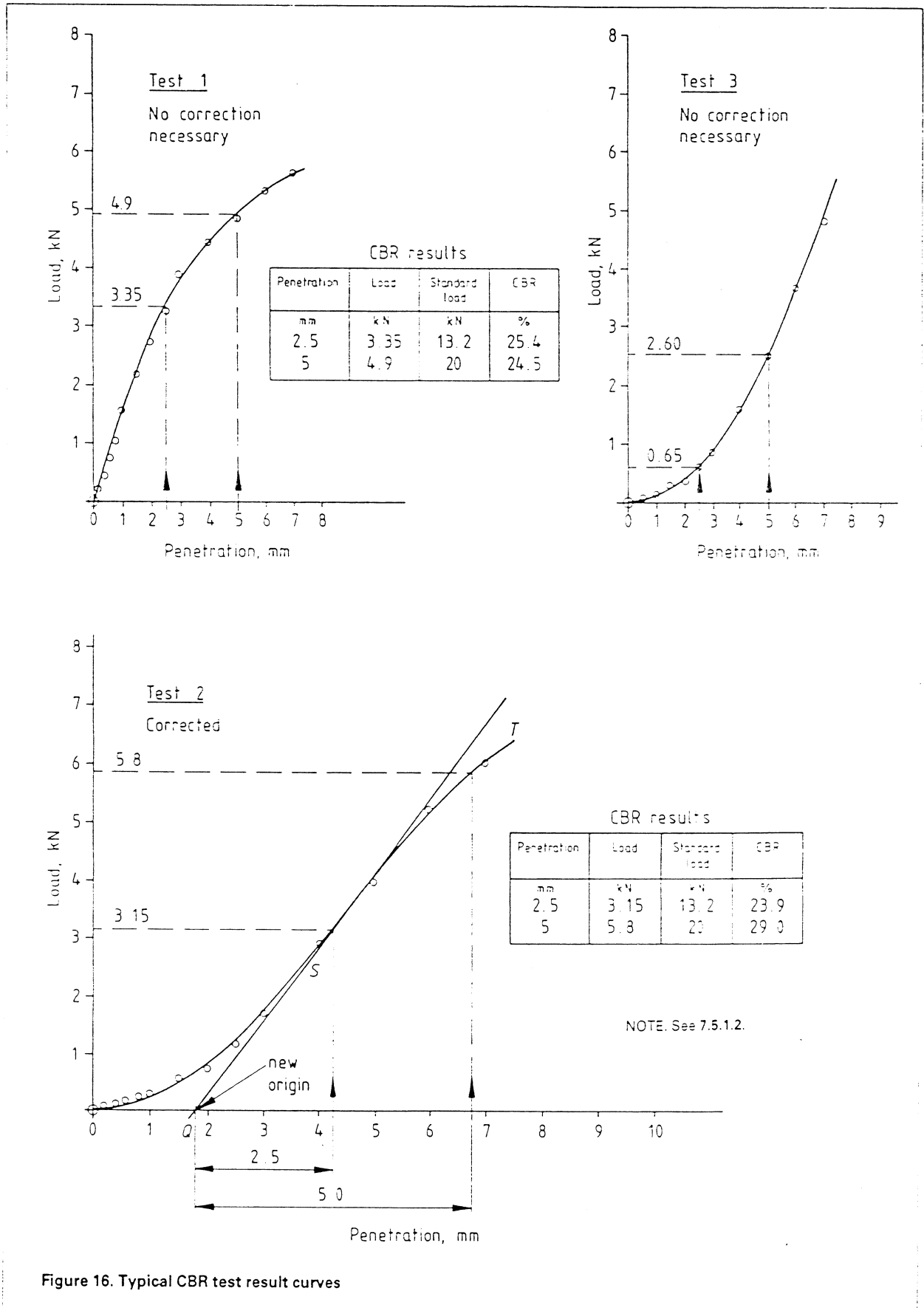

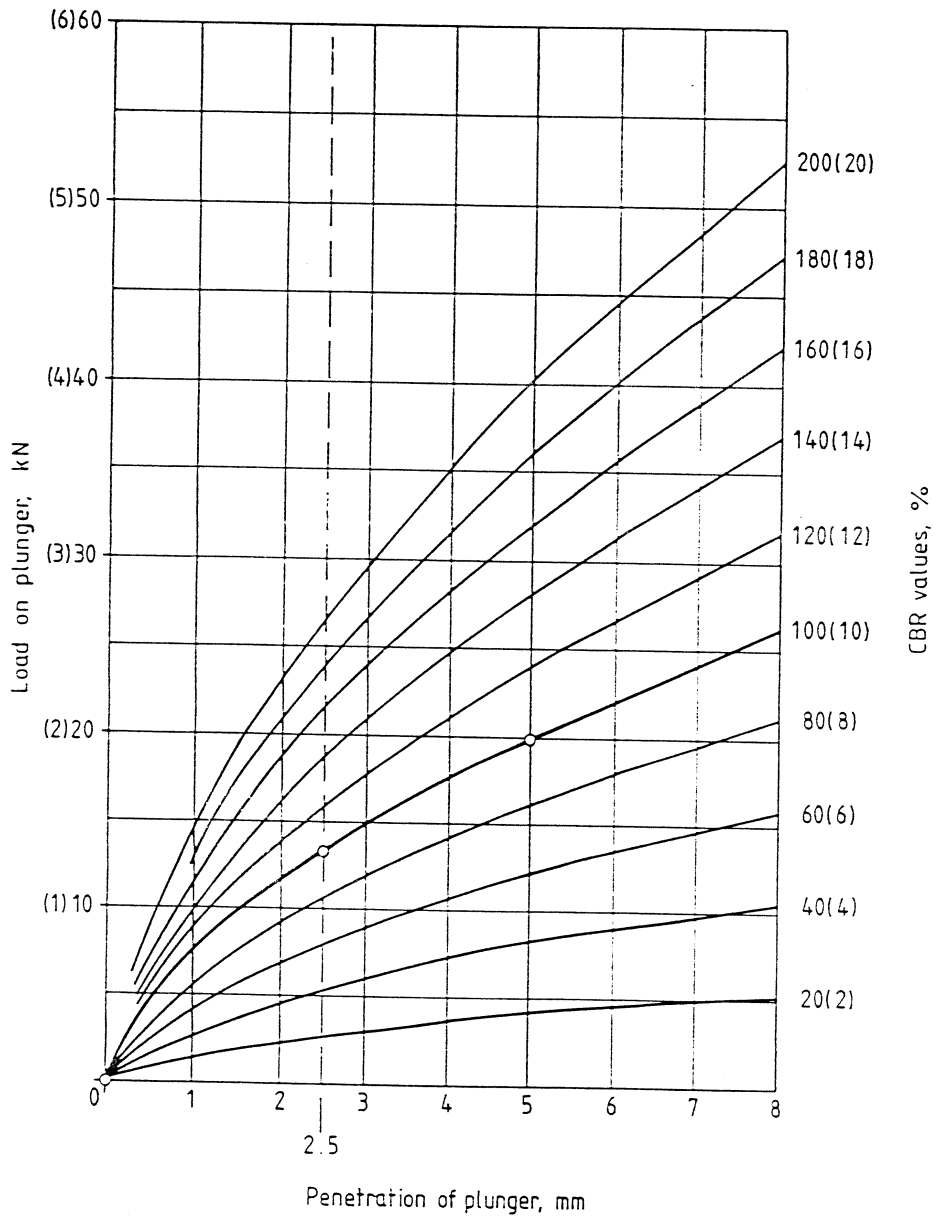

Figure 17. Force-penetration curves for a CBR value of 100 % and other CBR values

## Appendices

### Appendix A. Typical test data and calculation forms

The test sheets shown are given as examples; other suitable forms may be used.

Form	Title
4.A	Dry density/moisture content relationship (rammer)
4.B	Dry density/moisture content relationship (vibration)
4.C	Moisture condition value
4.D	Chalk crushing value
4.E	California Bearing Ratio test (data for density)
4.F	California Bearing Ratio test
4.G	California Bearing Ratio test (graph)

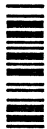

\*S\*





Moisture condition

Single sample/separate batches*	
Initial sample mass	g
Moisture content	g
Dry mass	g
Mass retained on 20 mm sieve	g
	%

Total number of blows <i>n</i>	Penetration or protrusion mm	Change in penetration <i>n</i> to 4 <i>n</i> min
1		
2		
3		
4		
6		
8		
12		
16		
24		
32		
48		
64		
96		
128		
192		
256		

Location	Job ref.
	Borehole/ Pit no.
Soil description	Sample no.
	Depth
	Date
Test method BS 1377 : Part 4 : 1990 : 5	
*Delete as appropriate	

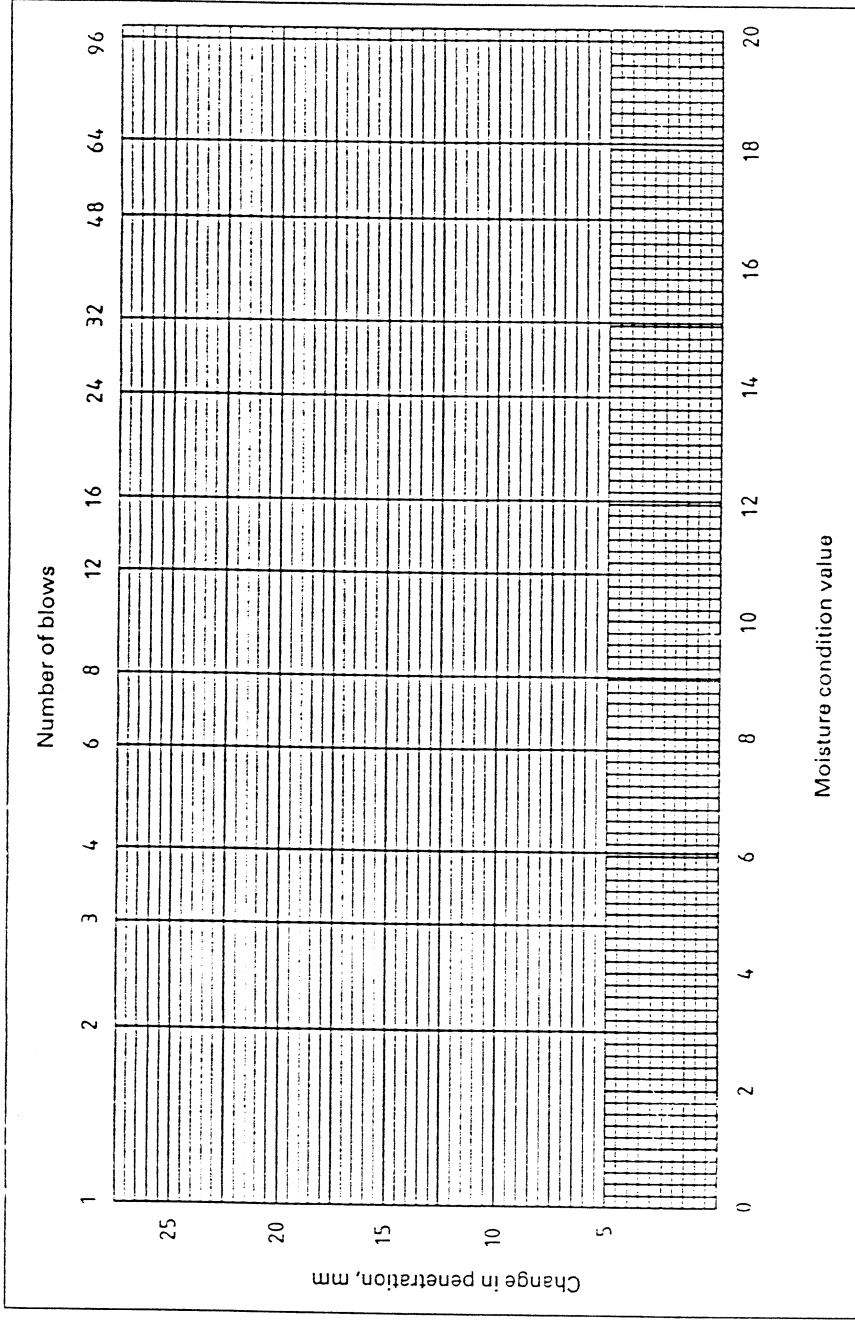

Operator	Checked	Approved
----------	---------	----------

Form 4:C

Chalk crushing value

Form 4.D

Location	Job ref.	
	Borehole/ Pit no.	
Soil description	Sample no.	
	Depth	m
Test method BS 1377 : Part 4 : 1990 6		
Initial sample mass	g	
Mass retained on 10 mm sieve	g	
Percentage retained on 10 mm sieve		
Moisture content*	%	
Saturation moisture content*	%	

Total number of blows	Penetration or protrusion mm					
	Specimen (1)	(2)	(3)	(4)	(5)	(6)
1						
2						
3						
4						
5						
6						
7						
8						
9						
10						
20						
30						
40						
50						
Chalk crushing value (CCV)						
Average CCV						

\*If required

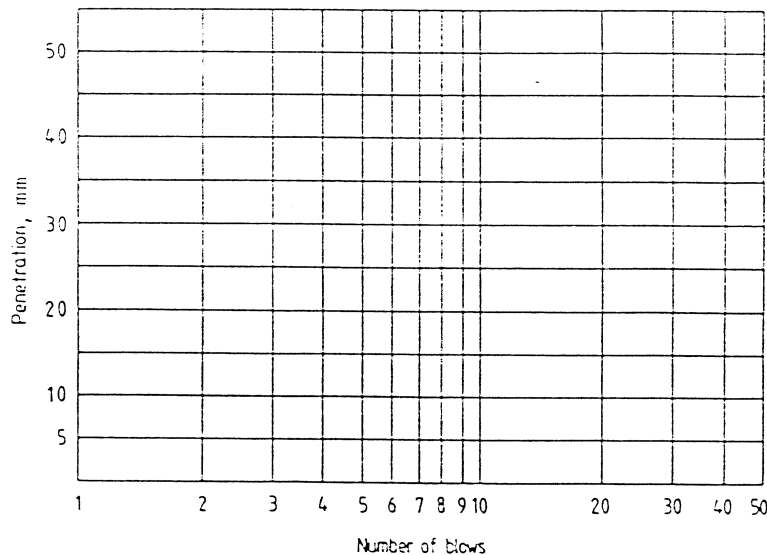

	Operator	Checked	Approved

California Bearing Ratio test (data for density)

Location		Job ref.	
		Borehole/ Pit no.	
Soil description		Sample no.	
		Depth	m
Sample preparation method		BS 1377 : Part 4 : 1990 : 7.2.3/7.2.4/7.2.5*	
Preparation procedure	Static, _____ layer(s), with/without tamping* 2.5 kg rammer/4.5 kg rammer/vibrating hammer*		
	Specified density* _____ Mg/m <sup>3</sup>	Volume of mould V _____ cm <sup>3</sup>	Specified effort* _____ layers _____ blows per layer
*Calculated mass of soil required (m <sub>1</sub> )		g	
*Mass of mould + baseplate + soil (m <sub>3</sub> )		g	
*Mass of mould + baseplate (m <sub>2</sub> )		g	
*Mass of soil (m <sub>3</sub> - m <sub>2</sub> )		g	
*Soaking time		days	
*Time for water to appear at top of sample			
*Final swell		mm	
*Mass of mould + baseplate + soil after soaking (m <sub>4</sub> )		g	
*Mass of soil after soaking (m <sub>4</sub> - m <sub>2</sub> )		g	
Maximum bearing ratio from plotting chart		%	
Bulk density (unsoaked)	* $\rho = \frac{m_1}{V}$		Mg/m <sup>3</sup>
	* $\rho = \frac{m_3 - m_2}{V}$		Mg/m <sup>3</sup>
Moisture content (w)		%	
*Dry density (unsoaked) $\rho_d = \frac{100 \rho}{100 + w}$		Mg/m <sup>3</sup>	
*Delete as appropriate			
		Operator	Checked
			Approved

Form 4.E



California Bearing Ratio test

Location					Job ref.						
					Borehole/ Pit no.						
Soil description					Sample no.						
					Depth		m				
Test method BS 1377 : Part 4 : 1990 : 7.4											
Force measuring device no.					Unsoaked/soaked*						
					Mean calibration				N/div		
Penetration of plunger mm		Force gauge reading div		Force on plunger kN		Penetration of plunger mm		Force gauge reading div		Force on plunger kN	
0		Top Bottom		Top Bottom		4.00		Top Bottom		Top Bottom	
0.25						4.25					
0.50						4.50					
0.75						4.75					
1.00						5.00					
1.25						5.25					
1.50						5.50					
1.75						5.75					
2.00						6.00					
2.25						6.25					
2.50						6.50					
2.75						6.75					
3.00						7.00					
3.25						7.25					
3.50						7.50					
3.75											
*Delete as appropriate											
Moisture content after test											
Container No.									CBR value at penetration of:		
Mass of wet soil + container ( $m_2$ )					g				2.5 mm		5.0 mm
Mass of dry soil + container ( $m_3$ )					g				Top	%	%
Mass of container ( $m_1$ )					g				Bottom		
Mass of moisture ( $m_2 - m_3$ )					g						
Mass of dry soil ( $m_3 - m_1$ )					g						
Moisture content $w = \frac{m_2 - m_3}{m_3 - m_1} 100$					%				Accepted CBR		%
Average moisture content					%						
					Operator		Checked		Approved		

Form 4.F

California Bearing Ratio test (graph)

Location		Job ref.		
		Borehole/ Pit no.		
Soil description		Sample no.		
		Depth	m	
Test method		BS 1377 : Part 4 : 1990 : 7.4		
*Delete as appropriate		Test on top face — ● — unsoaked/soaked*		
		Test on bottom face — x — unsoaked/soaked*		
Force on plunger, kN				
	Penetration of plunger, mm			
	0    0.5    1    2    3    4    5    6    7    7.5			
			Top face	Bottom face
	CBR % at penetration of		2.5 mm	
			5.0 mm	
			Operator	Checked
				Approved

Form 4.G

### **Publications referred to**

- BS 1377 \*Methods of test for soils for civil engineering purposes  
Part 1 General requirements and sampling  
Part 2 Classification tests  
\*Part 9 In-situ tests

This British Standard, having been prepared under the Road Engineering Standards Policy Committee, was published under the authority of the Board of the BSI and comes into effect on 31 August 1990

© British Standards Institution, 1990

First published in 1948

First published in metric in 1975

ISBN 0 580 18070 0

The following BSI references relate to the work on this standard:  
Committee reference RDB/38 Draft for comment 88/10676 DC

**British Standards Institution.** Incorporated by Royal Charter, BSI is the independent national body for the preparation of British Standards. It is the UK member of the International Organization for Standardization and UK sponsor of the British National Committee of the International Electrotechnical Commission.

In addition to the preparation and promulgation of standards, BSI offers specialist services including the provision of information through the BSI Library and Standardline Database; Technical Help to Exporters; and other services. Advice can be obtained from the Enquiry Section, BSI, Milton Keynes MK14 6LE, telephone 0908 221166, telex 825777.

**Copyright.** Users of British Standards are reminded that copyright subsists in all BSI publications. No part of this publication may be reproduced in any form without the prior permission in writing of BSI.

This does not preclude the free use, in the course of implementing the standard, of necessary details such as symbols and size, type or grade designations. Enquiries should be addressed to the Publications Manager, BSI, Linford Wood, Milton Keynes MK14 6LE. The number for telephone enquiries is 0908 220022 and for telex 825777.

**Contract requirements.** A British Standard does not purport to include all the necessary provisions of a contract. Users of British Standards are responsible for their correct application.

**Revision of British Standards.** British Standards are revised, when necessary, by the issue either of amendments or of revised editions. **It is important that users of British Standards should ascertain that they are in possession of the latest amendments or editions.**

**Automatic updating service.** BSI provides an economic, individual and automatic standards updating service call PLUS. Details are available from BSI Enquiry Section at Milton Keynes: telephone 0908 221166, telex 825777.

Information on all BSI publications is in the *BSI News* which is available to subscribing members of BSI and gives details of new publications, revisions, amendments and withdrawn standards. Any person who, when making use of a British Standard, encounters an inaccuracy or ambiguity, is requested to notify BSI without delay in order that the matter may be investigated and appropriate action taken.

## Committees responsible for this British Standard

The preparation of this British Standard was entrusted by the Road Engineering Standards Policy Committee (RDB-H) to Technical Committee RDB 38, upon which the following bodies were represented:

Association of Consulting Engineers  
British Civil Engineering Test Equipment Manufacturers' Association

County Surveyors' Society  
Department of the Environment (Property Services Agency)  
Department of the Environment (Building Research Establishment)  
Department of Transport  
Department of Transport (Transport and Road Research Laboratory)  
Co-opted members

## Amendments issued since publication

Amd. No.	Date of issue	Text affected

British Standards Institution · 2 Park Street London W1A 2BS · Telephone 071-629 9000 · Telex 266933